

Textured Spray Unit

E1702

OWNERS MANUAL



SealMaster®

Pavement Products & Equipment

PO Box 2277 • Sandusky, Ohio 44870 • 419-626-4375

sealmaster.net

TEXTURED SPRAY UNIT

Owner's Manual

Version 1.0

Issue Date: September 2025

Effective Date: October 2018

Version	Date	Changes	Approval
1.0	9/25	Original Issue	JG

Table of Contents

CORRESPONDENCE	2
SealMaster® LIMITED WARRANTY	3
SAFETY PRECAUTIONS AND CAUTIONS	5
PRECAUTIONS.....	5
CAUTIONS.....	5
TEXTURED SPRAY UNIT OPERATING INSTRUCTIONS	6
PRE-START CHECKLIST	6
STARTUP	7
1-STARTING THE ENGINE	7
2-PILOT VALVE ADJUSTMENT	8
3-DRAIN MOISTURE FROM THE AIR TANK	8
TEXTURED SPRAY UNIT OPERATING INSTRUCTIONS	9
START-UP.....	9
A-APPLICATION	9
B-ADJUSTMENTS	9
C-PREVENTION	9
D-CLEANING	9
E-MAINTENANCE.....	9
TEXTURED SPRAY UNIT	11
PARTS LIST PICTURE -1 MAIN ASSEMBLY	13
PARTS LIST PICTURE -2 FITTINGS.....	14
PARTS LIST PICTURE -3 APPLICATION GUN & STRAINER.....	16
PARTS LIST PICTURE -4 FILTER REGULATOR	17
PARTS LIST PICTURE -5 SURGE TANK & MUFFLER.....	18
PARTS LIST FOR ARO 1" PUMP	19
MACHINE MAINTENANCE.....	21
MAINTENANCE SCHEDULE	21
TROUBLESHOOTING GUIDE.....	24
MAINTENANCE AND STORAGE	25
MAINTENANCE	25
STORAGE	25

ThorWorks Industries, Inc.

Purchased by _____ Model NO. _____
Company Name _____ Serial NO. _____
Address _____ Acceptance Date _____
City _____ State _____ Zip _____

CORRESPONDENCE

All Correspondence regarding this equipment, as well as general correspondence should be addressed to:

ThorWorks Industries, Inc.

PO Box 2277

Sandusky, OH 44870

In referring to the equipment, kindly state the Model Number, Serial Number and any part number involved



SealMaster® LIMITED WARRANTY

SealMaster warrants that its products are of quality material and workmanship. SealMaster agrees to replace, within a period of one (1) year from date of delivery, or at its option, repair, without charge, any part of their manufacture which proved defective. The repair or replacement will be free of charge F.O.B. Sandusky, Ohio, providing the damaged part or parts are returned, freight prepaid, to SealMaster and investigation shows such repair or replacement is made necessary by an inherent defect of material or workmanship.

It is hereby understood that engines, motors, pumps, or other components purchased by SealMaster for use on its equipment are not warranted by SealMaster and are sold only with the standard warranty of the manufacturer of that component.

SealMaster will make no allowances for repairs or alterations completed by outside sources unless authorization is in writing and approved by an authorized SealMaster representative.

Any claims for defective material or workmanship must be made prior to the expiration of thirty (30) days from the date failure occurs, and in all cases prior to the expiration of the warranty period of one (1) year. It is the intent of this paragraph to limit SealMaster's liability solely to the cost of replacement parts, F.O.B. factory, or at the option of SealMaster to repair of the defective part or parts. No allowances for damages, lost time, or any other claim will be recognized.

This warranty is null and void if other than genuine SealMaster parts are used.

SealMaster is constantly striving to improve their products. Changes in design and improvement will be made whenever the manufacturer believes the efficiency of the product will be improved, without incurring any obligation to incorporate such improvements in any machines which have been shipped or are in service.

In an effort to continue to improve product quality, SealMaster reserves the right to change specifications without notice.

Any modification or alteration of this machine without prior approval of the manufacturer may void this warranty.

SAFETY PRECAUTIONS AND CAUTIONS

PRECAUTIONS

- You are operating a machine with compressed air.
- **Always** wear **eye** and **ear** protection and **gloves**.



- Be aware of all **CAUTION, WARNING, and DANGER** signs on the unit.
- All employees should be trained in **Emergency Burn First Aid**.
- Read all owner manuals that come with this unit.
- Make sure the operator is familiar with the units' operation.
- Replace any hoses that show signs of wear, fraying, or splitting.
- Be sure all fittings and joints are tight and leakproof.
- Do not operate this unit in the rain, an enclosed building, or a confined area.
- Do not do maintenance work on the machine while in operation.
- The machine should not be left unattended when running.

CAUTIONS

- Never refuel the engine while running
- Keep hands, feet, and clothing away from moving parts.
- Do not operate the machine without all guards in place.

TEXTURED SPRAY UNIT OPERATING INSTRUCTIONS

PRE-START CHECKLIST

Read the owner's manual thoroughly.

Ensure you completely understand all of the safety warnings, system controls, and instructions provided before attempting to operate this air compressor.

Every effort has been made to provide you with the information needed to obtain many years of reliable and trouble-free service from your new air compressor. It is your responsibility to operate the air compressor properly. You must always remember the following instructions to obtain your air compressor's longest possible service life.

1. ALWAYS OPERATE THE COMPRESSOR IN A LEVEL POSITION
2. OPERATE IN A CLEAN, DRY, AND WELL-VENTILATED AREA
3. CHECK OIL LEVEL DAILY AND CHANGE AT REGULAR INTERVALS
4. INSPECT/CLEAN/CHANGE INTAKE ELEMENTS REGULARLY
5. USE LONGER, PROPERLY SIZED AIR HOSES
6. **DO NOT** USE A GENERATOR AS THE POWER SOURCE
7. CHECK TENSION OF BOLTS, BELTS, AND HARDWARE REGULARLY
8. MAINTAIN RUBBER VIBRATION PADS
9. DRAIN MOISTURE FROM AIR TANKS DAILY
10. **DO NOT** ALTER FACTORY RPM SETTINGS ON GAS-POWERED COMPRESSORS

TEXTURED SPRAY UNIT OPERATING INSTRUCTIONS

STARTUP

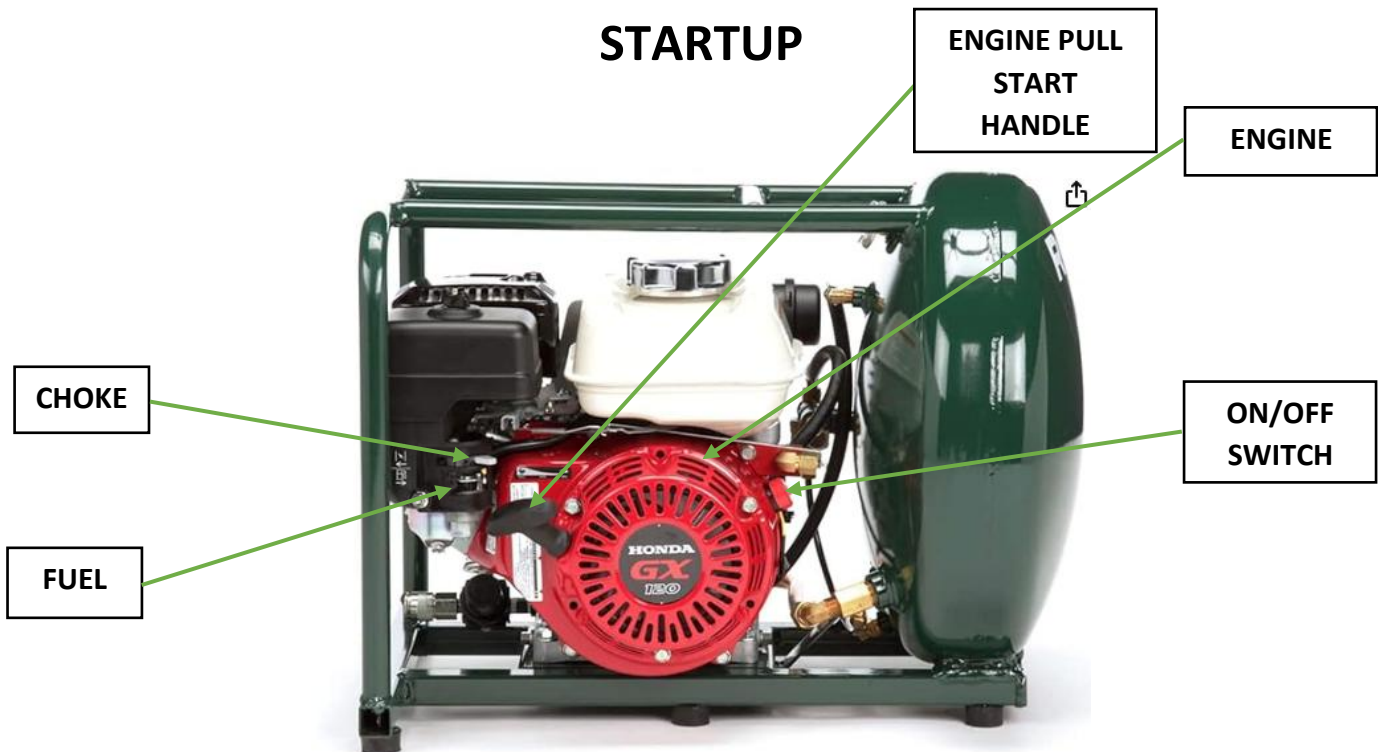

1-STARTING THE ENGINE

- Set the **fuel** shutoff and **choke** levers to the **open** position.
- Set the engine **on/off** switch to the **on** position.
- Pull Start the **engine**.
- Gradually move the **choke** lever to the **closed** position.
- The engine operates at a fixed RPM. Let it run for five minutes.

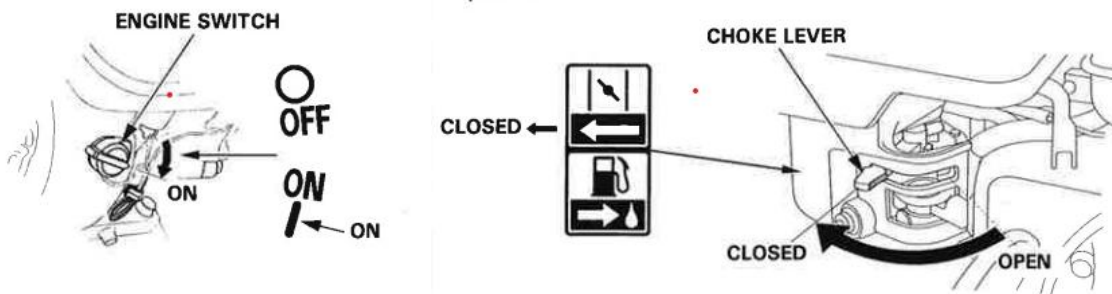

TEXTURED SPRAY UNIT OPERATING INSTRUCTIONS

STARTUP



PILOT VALVE
ADJUSTMENT

DRAIN COCK

2-PILOT VALVE ADJUSTMENT

PILOT VALVE ADJUSTMENT

RESETTING DIFFERENTIAL (2)

Make sure the top toggle lever is positioned as shown. (See Figure 3). Loosen locknut (1) by turning counterclockwise several full turns. Gently turn differential setting (2) clockwise only until the internal rod makes contact with the steel ball inside. After making contact, turn differential (2) counterclockwise 1/4 turn. Secure position by tightening locknut (1) and proceed to top end setting.

TOP-END SETTING (4)

Loosen locknut (3) by turning counterclockwise several full turns. (4) is the top end setting. Turning (4) clockwise will increase the top end pressure setting. Turning counterclockwise will decrease the top end pressure setting. Begin at a low setting by turning counterclockwise one full turn. Proceed to fine tuning instructions.

FINE-TUNING INSTRUCTIONS

Start engine/motor and observe tank pressure gauge. As tank pressure approaches 100-130 P.S.I.G., the pilot valve should begin unloading at felt muffler and cause gas engine to slow down to idle speed. If pilot valve does not unload as tank pressure approaches 130 P.S.I.G., slowly turn top end setting (4) counterclockwise until pilot starts to unload prematurely (at 100 P.S.I.G.), turn top end setting (4) clockwise in 1/4 turn increments, tap down on the internal rod at toggle attachment and repeat until desired top end setting is reached. If pilot valve begins to rattle (sputter), fine tune differential setting (2) 1/16 turn in either direction until rattling stops. After fine tuning, secure setting by turning locknuts (1 & 3) clockwise until tight. Hold setting (2 & 4) in place while turning locknuts to secure.

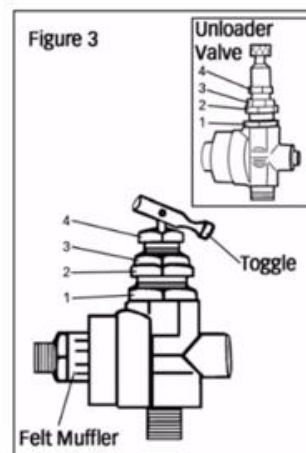

3-DRAIN MOISTURE FROM THE AIR TANK

- DRAIN MOISTURE FROM THE TANK EVERY **8 HOURS**

TEXTURED SPRAY UNIT OPERATING INSTRUCTIONS

START-UP

Open the bucket and completely mix in the liquid tint. Place on the cart and insert the suction hose assembly #11. Leave all Suction and material ball valve #16 closed. Start air compressor #9 and wait for the compressor to fill the air receiver tank.

Then the Material pump regulator #4 should be set for **80 psi**. Now lower the material ball valve #16; this will allow the material pump #3 to start.

Applicator gun regulator #6 should be set for **40 psi**. Turn the knob **clockwise** to increase pressure, and **counter-clockwise** to decrease pressure.

A-APPLICATION

Uncoil as much $3/8''$ hose #1 and $5/8''$ hose #2 as much as you want, place the applicator gun #14 about 18-30 inches from the surface, and pull **the trigger**, spraying just enough product to coat. Overlap by half. Follow with a soft-bristle broom to work it evenly into the asphalt.

B-ADJUSTMENTS

At the end of the applicator gun, **#14** is an air adjustment valve used to fine-tune the spray intensity. Use this control to achieve a uniform round spray pattern. Behind **the trigger** is an **adjustment wheel nut**, which controls the flow rate of the product. Adjustment can only be achieved with the trigger released.

C-PREVENTION

Use **8-12 mm nozzle tips**. Keep a small amount of air flowing through the applicator gun #14. This prevents material from backing up the **needle assembly**.

D-CLEANING

Flush the system completely with water when finished. Remove the suction hose assembly #11 from the bucket. Engage **the trigger lock** on the applicator gun #14 so it cannot be activated. Remove the **nozzle tip** and hold the gun over the product bucket. Release **the trigger lock** and spray material into the bucket, stopping when it is obvious air is starting to come out. Place the suction hose assembly #11 into a bucket of water and continue pumping until the water stream is clear.

E-MAINTENANCE

For the long life of the applicator gun #14, dismantle the gun, completely clean, and lightly oil the **needle assembly**.

TEXTURED SPRAY UNIT OPERATING INSTRUCTIONS

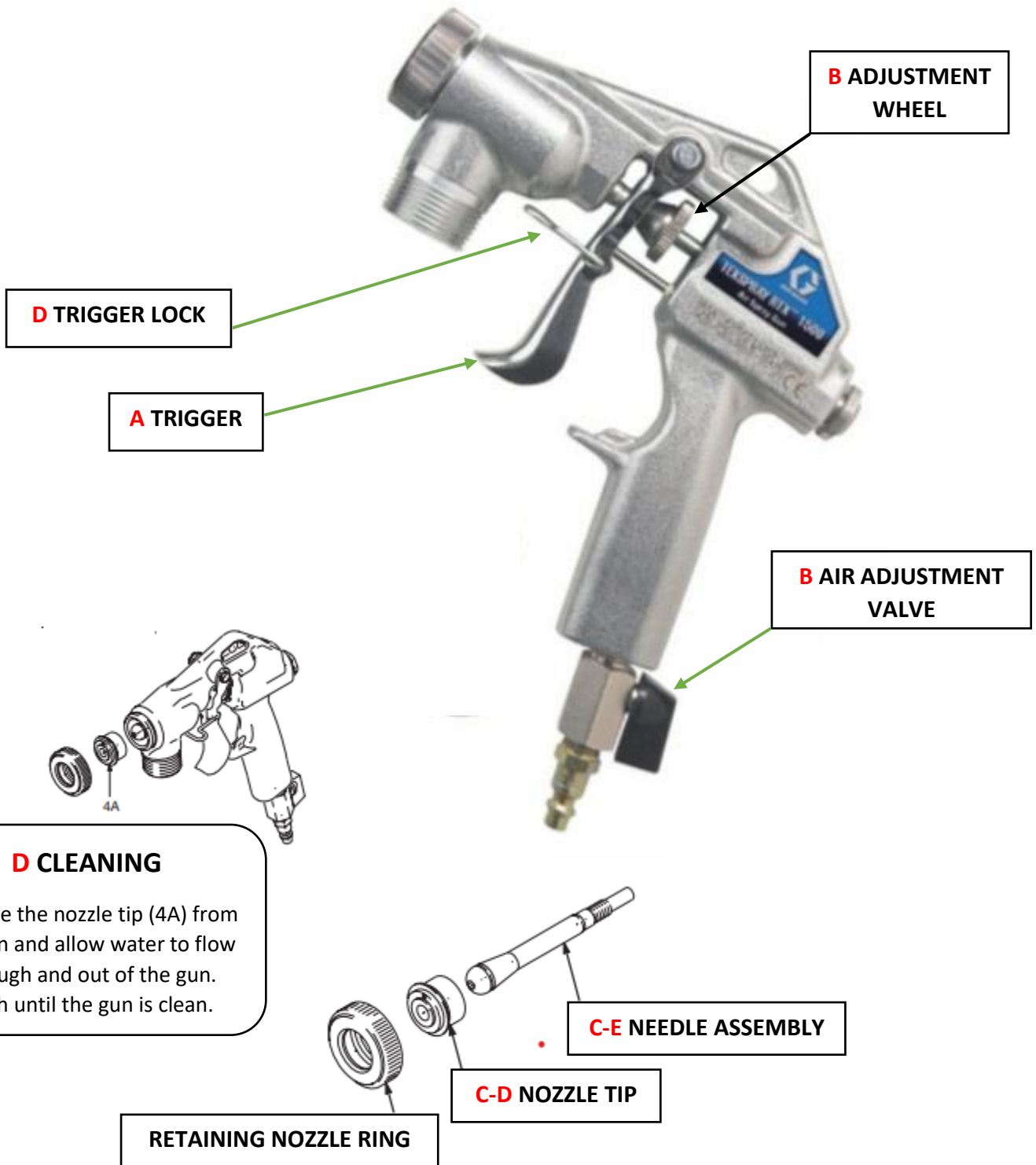

TEXTURED SPRAY UNIT MACHINE PICTURES AND PARTS LIST

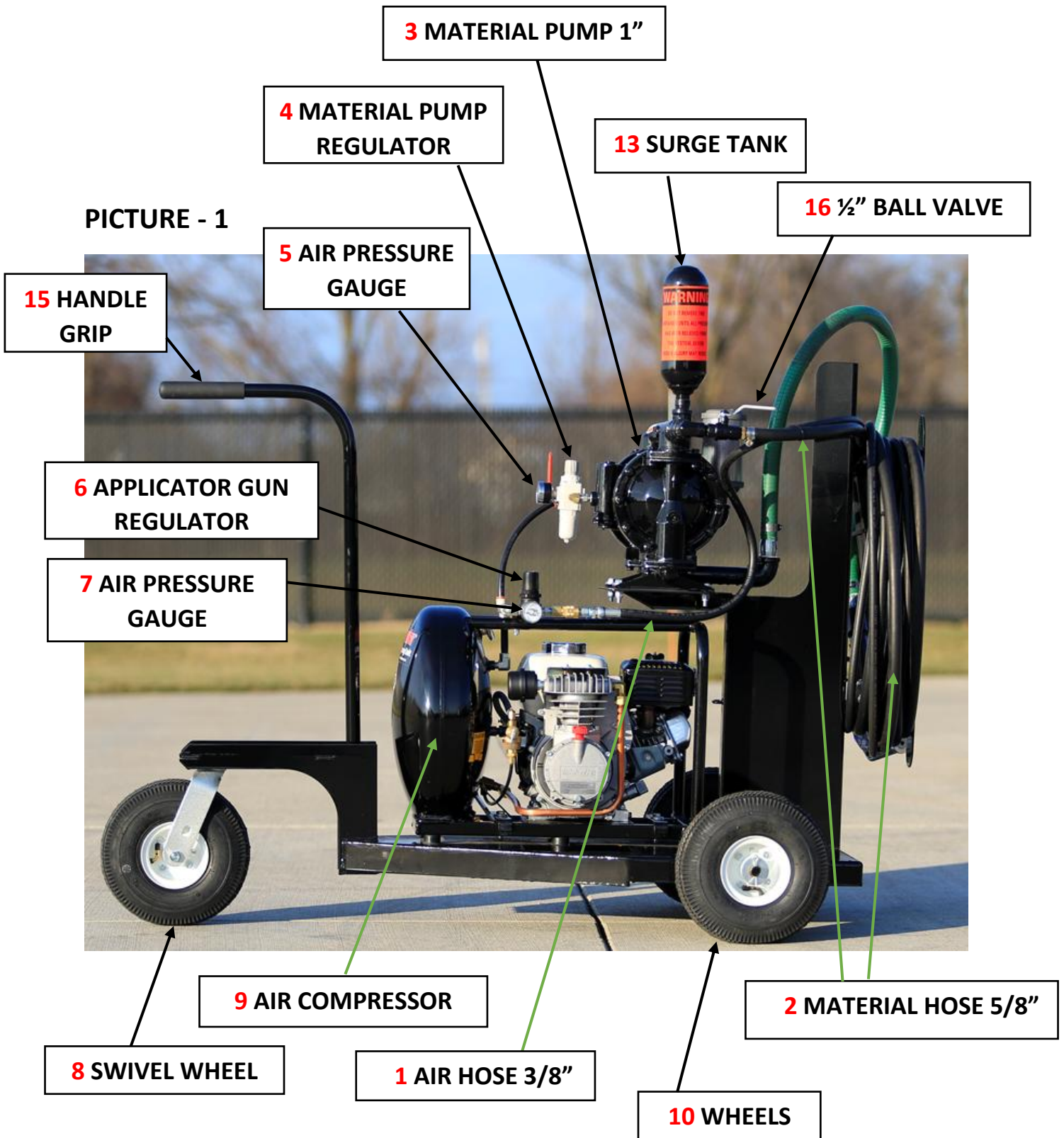

TEXTURED SPRAY UNIT

MACHINE PICTURES AND PARTS LIST

PICTURE -1



1 AIR HOSE 3/8" 28FT.

2 MATERIAL HOSE 5/8" 25FT.

14 APPLICATOR GUN

12 INLET STRAINER

11 SUCTION HOSE ASSEMBLY



20 MUFFLER

19 EXHAUST DEFLECTOR

21 PILOT UNLOAD VALVE

18 RUBBER FEET

17 HOLD DOWN

TEXTURED SPRAY UNIT

MACHINE PICTURES AND PARTS LIST

PARTS LIST PICTURE -1 MAIN ASSEMBLY

ITEM #	PART#	QTY.	DESCRIPTION
1	P717E000	1	3/8" AIR HOSE 28FT.
2	P712E000	1	5/8" MATERIAL HOSE 25FT.
3	P640A060	1	1" MATERIAL PUMP
	P975A059	1	1" MATERIAL PUMP REBUILT KIT
4	P735A046	1	MATERIAL PUMP REGULATOR W/GAUGE
5	P735A048	1	AIR PRESSURE GAUGE (ONLY)
6	P735A023	1	APPLICATOR GUN REGULATOR
7	P735A027	1	AIR PRESSURE GAUGE (ONLY)
8	P579A001*	1	SWIVEL WHEEL
9	P458A051	1	AIR COMPRESSOR & 4HP ENGINE
10	P514A005	2	WHEELS
11	P71000C001	1	SUCTION HOSE ASSEMBLY
12	P159A477	1	1" INLET STRAINER
13	P30003E	1	SURGE TANK
14	P159A465	1	APPLICATOR GUN
15	P481A	1	HANDLE GRIP
16	P397A009	1	1/2" BALL VALVE
17	P81000B028	2	HOLD DOWN
18	P458C034	4	RUBBER FEET
19	P458B110	1	EXHAUST DEFLECTOR
20	P976A053	1	MUFFLER
21	P458C017	1	PILOT UNLOAD VALVE

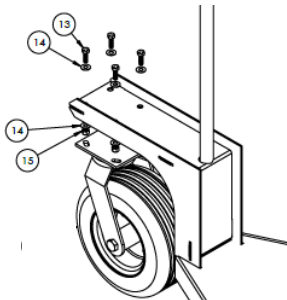

**ITEMS # 13-14-15 ARE
FOR SWIVEL DETAIL**

13	1014A009	5/16"-18 HEX HEAD CAP SCREW 1" LONG	4
14	1017A002	5/16" WASHER FLAT	8
15	1021A005	5/16-18 LOCKNUT	4

8 SWIVEL WHEEL DETAIL*

TEXTURED SPRAY UNIT

MACHINE PICTURES AND PARTS LIST

PICTURE - 2

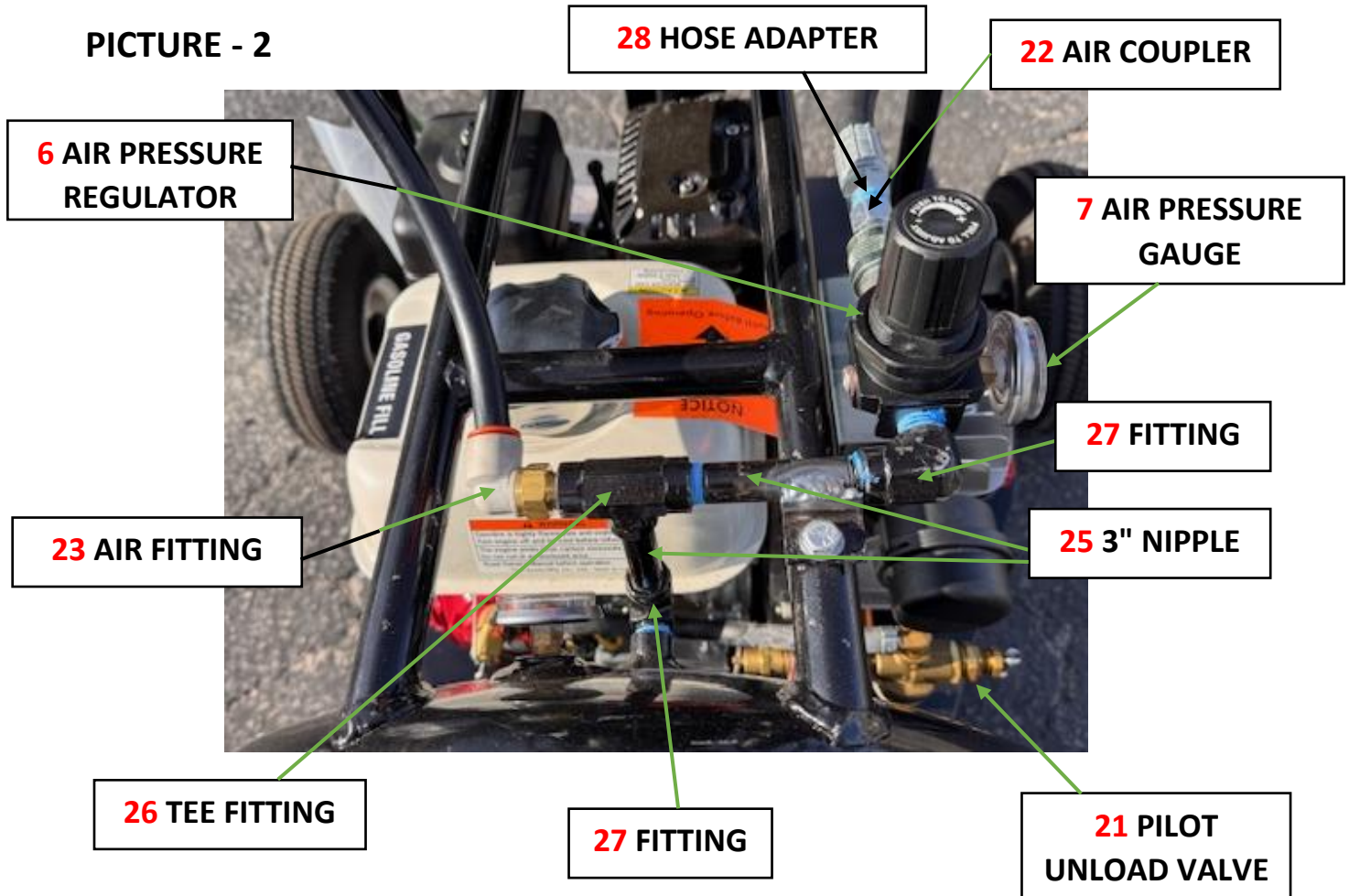

PARTS LIST PICTURE -2 FITTINGS

ITEM #	PART#	QTY.	DESCRIPTION
21	P458C017	1	PILOT UNLOAD VALVE
22	P571A001	1	1/4" FEMALE AIR COUPLER
23	P560A055	1	1/2" TUBE x 1/4" NPT AIR FITTING
6	P735A023	1	AIR PRESSURE REGULATOR
7	P735A027	1	AIR PRESSURE GAUGE
25	P1000A048	2	1/4" x 3" NIPPLE SCH 40
26	P560A021	1	1/4"FP-1/4"FP-1/4"FP TEE FITTING
27	P560A014	2	5502-04-04F FITTING
28	P571A008	1	1/4" AIR ADPT-MALE x FEMALE THREADS

TEXTURED SPRAY UNIT

MACHINE PICTURES AND PARTS LIST

PICTURE - 3

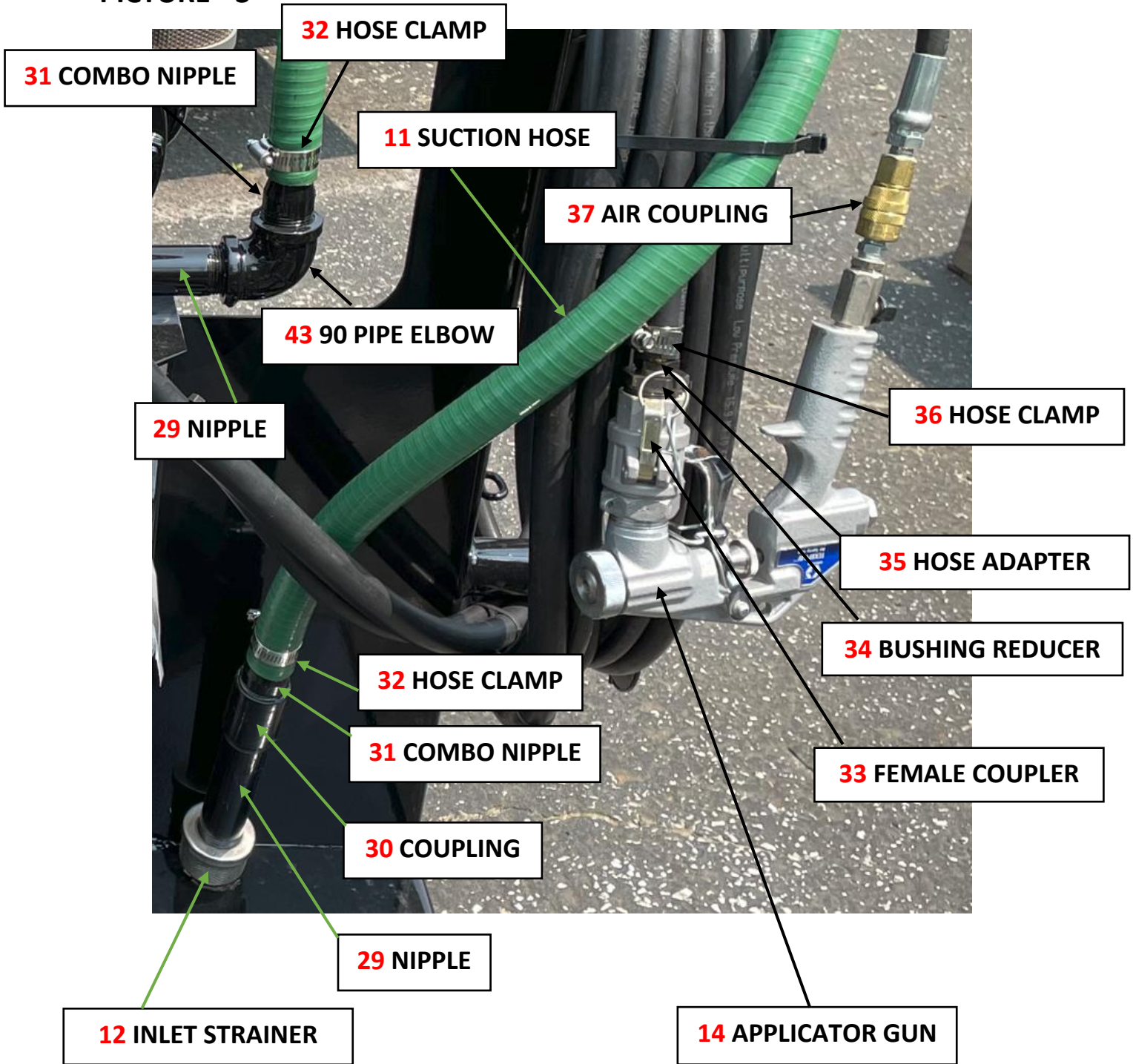

TEXTURED SPRAY UNIT

MACHINE PICTURES AND PARTS LIST

PARTS LIST PICTURE -3 APPLICATION GUN & STRAINER

ITEM #	PART#	QTY.	DESCRIPTION
12	P159A477	1	1" INLET STRAINER
29	P1000A021	2	1" x 6" NIPPLE SCH 40
30	P1002A004	1	1" COUPLING SCH 40
31	P1012A004	2	1" COMBO NIPPLE
32	P1023A005	2	13/16" HOSE CLAMP
14	P159A465	1	APPLICATOR GUN
11	P71000C001	1	SUCTION HOSE ASSEMBLY
33	P477A017	1	1" FEMALE COUPLER x FEMALE NPT
34	P1010A016	1	1" x 1/2" BUSHING REDUCER
35	P1012A011	1	5/8"ID x 1/2"M HOSE ADAPTER
36	P1023A003	1	#10 9/16"-11/16"" SS HOSE CLAMP
37	P571A001	1	1/4" FEMALE AIR COUPLER
38	P751A005	1	1/4 HOSE X 1/4 PIPE BRASS HOSE END
43	P1003A003	1	1" 90 PIPE ELBOW SCH 40
16	P397A009	1	1/2" BALL VALVE
20	P976A053	1	MUFFLER

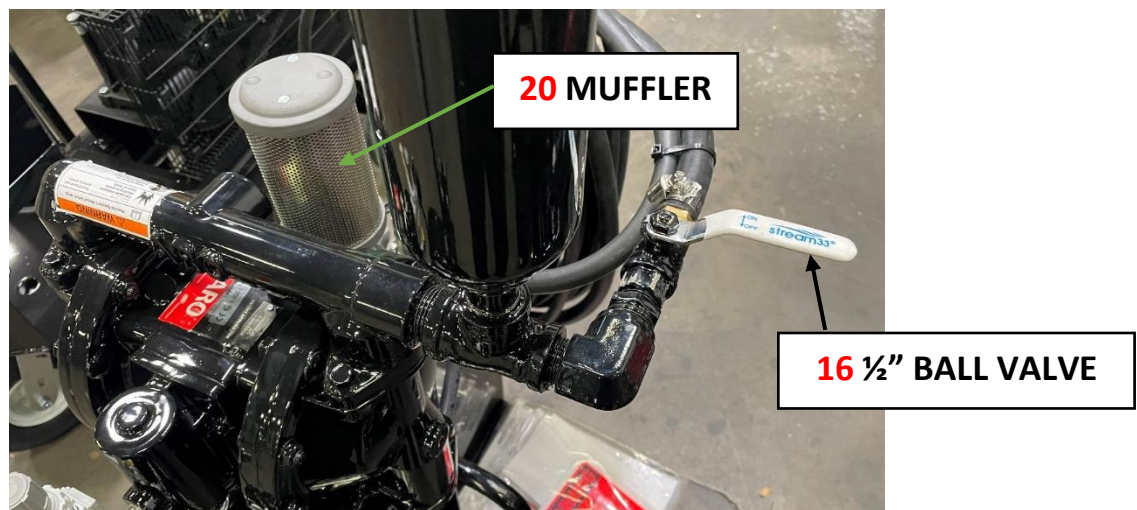

TEXTURED SPRAY UNIT

MACHINE PICTURES AND PARTS LIST

PICTURE - 4

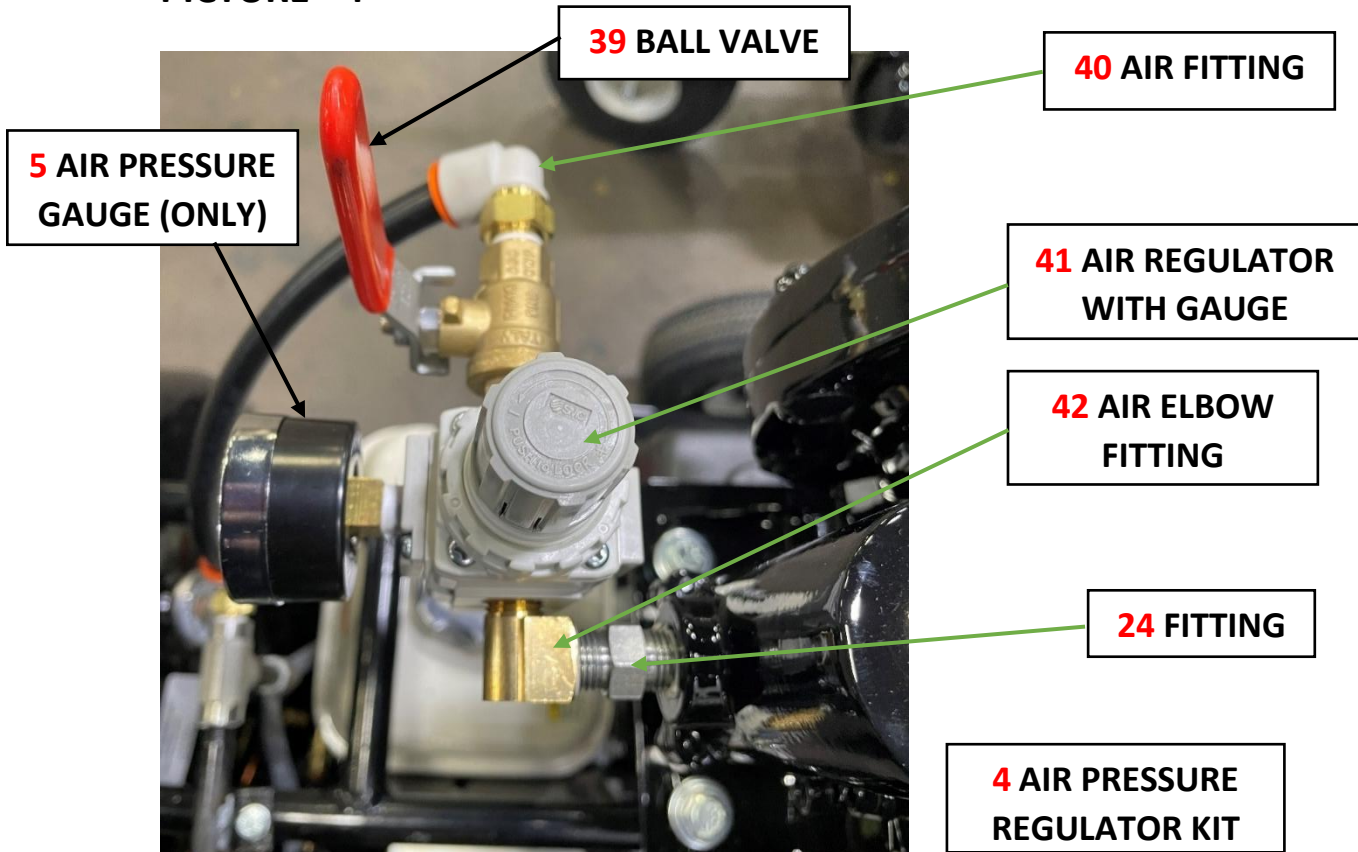

PARTS LIST PICTURE -4 FILTER REGULATOR

ITEM #	PART#	QTY.	DESCRIPTION
4	P735A046	1	AIR PRESSURE REGULATOR KIT
5	P735A048	1	AIR PRESSURE GAUGE (ONLY)
39	P397A033	1	1/4" MALE X 1/4" FEMALE BALL VALVE
40	P560A055	1	1/2" TUBE x 1/4" NPT AIR FITTING 90° MALE
41	P735A020	1	REGULATOR WITH GAUGE
42	P560A063	1	AIR FITTING-1/4" M X 1/4" F ELBOW 90°
24	P560A006	1	5404-04-04 FITTING

TEXTURED SPRAY UNIT

MACHINE PICTURES AND PARTS LIST

PARTS LIST PICTURE -5 SURGE TANK & MUFFLER

ITEM #	PART#	QTY.	DESCRIPTION
*1	P640A060	1	1" MATERIAL PUMP
2	P1000A021	1	1" x 6" NIPPLE SCH 40
3	P1000A011	2	3/4" x 2" NIPPLE SCH 40
4	P1003A002	1	3/4" 90 PIPE ELBOW SCH 40
5	P1000A016	1	1" CLOSE NIPPLE SCH 40
6	P560A042	1	5502-12-08F Hyd. Fitting
7	P397A009	1	1/2" BALL VALVE
8	P1000A004	1	1/2" CLOSE NIPPLE SCH 40
9	P30003E	1	SURGE TANK
10	P1009A001	1	1" x 3/4" x 3/4" RED TEE SCH 40
11	P1012A011	1	5/8" ID x 1/2" M HOSE ADAPTER
12	P560A006	1	5404-04-04 FITTING
13	P735A046	1	AIR PRESSURE REGULATOR W/GAUGE
14	P1017A002	8	5/16" WASHER-FLAT-ZINC
15	P1021A001	4	3/8"-16 NYLON INSERT LOCKNUT
16	P976A053	1	MUFFLER-ARO 1"
17	P1014A019	4	3/8"-16 x 1-1/2" HEX CAPSCREW GR5
18	P1003A003	1	1" 90 PIPE ELBOW SCH 40
19	P1012A004	1	1" COMBO NIPPLE
20	P1017A004	4	7/16" WASHER-FLAT-ZINC

***1 SEE PARTS LIST FOR
1" MATERIAL PUMP**

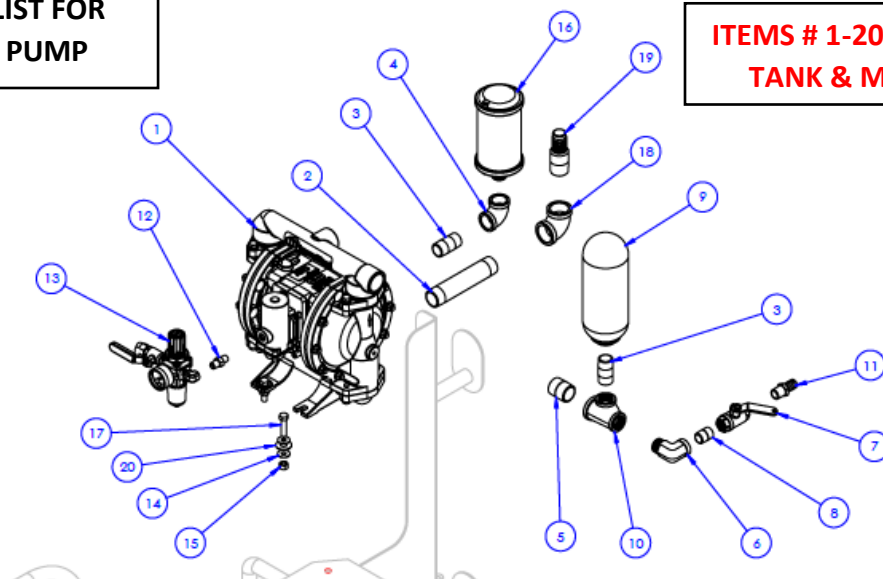

**ITEMS # 1-20 ARE FOR SURGE
TANK & MUFFLER ONLY**

PARTS LIST FOR ARO 1" PUMP

DESCRIPTION	S/M PART #	QTY.
ARO 1" PUMP	P640A060	1
AIR VALVE KIT	P975A060	1
GASKET	P975A019	2
O-RING 3/32" X 13/16" O.D.	P975A022	2
WASHER .406 I.D. X .031" THICK	P975A023	4
GASKET-TRACK	P976A031	1
GASKET	P975A037	1
U CUP 3/16" X 1-5/8" O.D.	P975A038	1
U CUP 3/16" X 1-1/8" O.D.	P975A039	1
GASKET-TRACK	P976A041	2
PILOT PISTON - WITH O-RING & U CUP	P975A043	1
O-RING 3/32" X 1-1/8" O.D.	P975A047	1
O-RING 1/16" X 1-1/8" O.D.	P975A048	1
O-RING 3/32" X 1-3/8" O.D.	P975A049	2
O-RING 1/8" X 1/2" O.D.	P975A050	2
DIAPHRAGM CHECK VALVE	P975A051	2
GASKET	P975A053	1
FML-2 GREASE	P975A056	1
MATERIAL PUMP REBUILD KIT	P975A059	1
DIAPHRAGM HYTREL	P975A004	2
SEAT- HYTREL	P975A008	4
BALL- HYTREL	P975A009	4
GASKET	P975A019	2
U CUP 3/16" X 1-1/8" O.D.	P975A021	2
FML-2 GREASE	P975A056	1

*** Note: Refer to the owner's manual or call customer service for additional parts.**

PARTS LIST FOR ARO 1" PUMP

DESCRIPTION	S/M PART #	QTY.
ARO 1" PUMP	P640A060	1
MAJOR VALVE KIT	P975A058	1
SCREW	P975A027	
SPOOL	P975A028	
PIPE PLUG	P975A031	
GASKET	P976A031	
VALVE BLOCK	P975A035	
END CAP	P975A036	
GASKET	P975A037	
U CUP	P975A038	
U CUP	P975A039	
VALVE INSERT	P975A040	
VALVE PLATE	P975A041	
GASKET	P976A041	
DIAPHRAGM – CHECK VALVE	P976A050	
GASKET	P976A052	
ADAPTER PLATE	P976A054	
MUFFLER	P976A053	1

* Note: Refer to the owner's manual or call customer service for additional parts.

TEXTURED SPRAY UNIT

MACHINE MAINTENANCE

MAINTENANCE SCHEDULE

MAINTENANCE

Your new air compressor represents the finest engineering and construction available. Even the best machinery requires periodic maintenance. Please stick to the maintenance schedule and consider the suggestions that follow to keep your compressor in peak condition.

NOTE: Always unplug or shut down your compressor and drain the air tanks completely before attempting any type of maintenance. Wait for the compressor to cool before servicing.

IMPORTANT: Replace the oil after the first 50 hours of operation.

MAINTENANCE HINTS: 1) Use a soap/water solution to check for air leaks.

2) Never clean filters with a flammable solvent.

3) Retorque head bolts only after the pump has cooled.

4) Never weld on air tank(s).

5) Use heat to loosen Loctite seal on the drain valves, engine pulleys and flywheels before attempting to remove.

LUBRICATION

Prior to each use, make a habit of checking the pump oil level. Most direct-drive air compressors have a dipstick with casting marks that indicate the minimum and maximum acceptable levels of oil.

Do not operate the pump with an inadequate or excessive amount of oil. The cost of failures which occur due to incorrect oil levels will not be covered under warranty.

DO NOT USE A DETERGENT OIL!

NOTE: Unit must be level when in operation



TEXTURED SPRAY UNIT

MACHINE MAINTENANCE

MAINTENANCE-CONTINUED

MAINTENANCE (continued)

PILOT VALVE ADJUSTMENT

NOTE: Should only be performed by ROLAIR factory authorized personnel.

RESETTING DIFFERENTIAL (2)

Make sure the top toggle lever is positioned as shown. (See Figure 3). Loosen locknut (1) by turning counterclockwise several full turns. Gently turn differential setting (2) clockwise only until the internal rod makes contact with the steel ball inside. After making contact, turn differential (2) counterclockwise 1/4 turn. Secure position by tightening locknut (1) and proceed to top end setting.

TOP-END SETTING (4)

Loosen locknut (3) by turning counterclockwise several full turns. (4) is the top end setting. Turning (4) clockwise will increase the top end pressure setting. Turning counterclockwise will decrease the top end pressure setting. Begin at a low setting by turning counterclockwise one full turn. Proceed to fine tuning instructions.

FINE-TUNING INSTRUCTIONS

Start engine/motor and observe tank pressure gauge. As tank pressure approaches 100-130 P.S.I.G., the pilot valve should begin unloading at felt muffler and cause gas engine to slow down to idle speed. If pilot valve does not unload as tank pressure approaches 130 P.S.I.G., slowly turn top end setting (4) counterclockwise until pilot starts to unload prematurely (at 100 P.S.I.G.), turn top end setting (4) clockwise in 1/4 turn increments, tap down on the internal rod at toggle attachment and repeat until desired top end setting is reached. If pilot valve begins to rattle (sputter), fine tune differential setting (2) 1/16 turn in either direction until rattle stops. After fine tuning, secure setting by turning locknuts (1 & 3) clockwise until tight. Hold setting (2 & 4) in place while turning locknuts to secure.

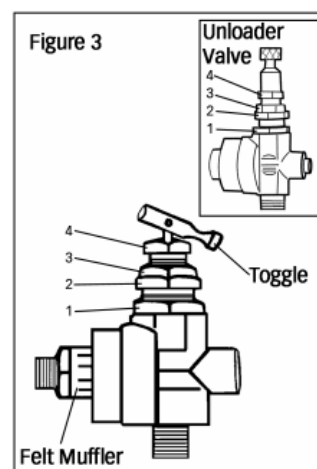

GASOLINE ENGINE RPM SETTINGS			
Model	Top RPM	Idle RPM	Pump RPM
GD4000PV5H	3100	1800	1800-3100

NOTE: Engine RPM's (High – Low Settings) are factory set for maximum efficiency. Adjusting RPM's above factory specification will void the warranty.

CHANGE ENGINE OIL* OIL SPECIFICATIONS / REFER TO ENGINE MANUAL

Honda Recommends **20hrs** Initial Start / every **100hrs** or 6 mons. After

TEXTURED SPRAY UNIT MACHINE MAINTENANCE

TROUBLESHOOTING GUIDE

TROUBLESHOOTING

WARNING - Make sure you completely understand all of the safety warnings and operation of each system control component before attempting any maintenance or repair. Always drain the tank pressure completely, make sure the power cord is unplugged, and unit has time to cool before performing any maintenance or service operations.

PROBLEM	CAUSE	SOLUTION
Pump is slow to build tank pressure	Excessive leaks in system	Correct air leaks
	Blown gasket	Replace head gaskets
	Broken reed valve	Replace reed valves
	Obstructed intake filter	Clean or replace intake element
	Leaking regulator	Replace regulator
	Defective pilot valve	Replace pilot valve
Excessive oil consumption	Too much oil in crankcase	Drain to proper level
	Improper weight of oil	Replace with proper oil
	Obstructed crankcase vent	Replace dipstick or oil fill plug/crankcase vent
	Dirty/plugged intake filter	Clean/replace intake filter
	Worn piston rings	Take unit in for service
	Scored cylinder	Take unit in for service
Knocking noise	Internal pump problem	Take unit in for service
Overheating compressor	Poor ventilation	Relocate compressor
	Internal pump problem	Take unit in for service
Gasoline engine is hard to start	Fouled, incorrect, or improperly gapped spark plug	Install proper spark plug after gapping to factory specs
	Improper engine oil level	Fill to top of threads for oil plug
	Improper weight of pump or engine oil	Change to proper weight of oil for operating temperature
	Improper or old gas	Take unit in for service

MAINTENANCE AND STORAGE

MAINTENANCE

During the lubrication stop, inspect all operating parts. If any damage or excessive wear is evident, replace the parts immediately. Straighten any parts as soon as possible. Clean and re-paint all exposed parts using touch-up kit P3020B034 **yellow** paint or touch-up kit P3020B033 **black** paint.

STORAGE

Perform all required maintenance and lubrication procedures. Coat all shafts with grease. Clean and re-paint all exposed parts using touch-up kit P3020B034 **yellow** paint or touch-up kit P3020B033 **black** paint.

Each touch-up kit includes:

1-pint paint can --- 1 pair of gloves --- 1 touch-up paintbrush

**FUTURE COMPRESSOR SET-UP
WITH **GX160** (GD5000PV5H-0094)**

Note: When ordering parts for Honda Engine, be sure to specify what **model** you have, **GX120** or **GX160** and **serial number**.

