

SP 575 Squeegee Machine

Operating Instructions & Parts Manual



SealMaster[®]

Pavement Products & Equipment

PO Box 2277 • Sandusky, Ohio 44870 • 419-626-4375

SealMaster[®]

ThorWorks Industries, Inc.

Item Purchased: _____ Model No.: _____
Serial No.: _____ Acceptance/Ship Date: _____
Company: _____ Contact: _____
Address: _____ City: _____
Zip/Postal Code: _____ State: _____ Country: _____

CORRESPONDENCE

All correspondence regarding this equipment or general correspondence should be addressed to:

ThorWorks Industries, Inc.
PO Box 2277
Sandusky, OH 44870

In referring to the equipment, kindly state the Model Number, Serial Number and any Part Number involved.





ThorWorks Industries Inc. Limited Warranty for Equipment

ThorWorks warrants that its products are of quality material and workmanship. ThorWorks agrees to replace, within a one (1) year period from date of delivery, or at its option, repair without charge, any part of their manufacture which proved defective. The repair or replacement will be free of charge F.O.B. Sandusky Ohio, providing the damaged part or parts are returned freight prepaid to ThorWorks and investigation show such repair or replacement is made necessary by inherent defect of material or workmanship. Obvious damage by misuse or abuse voids any liability on ThorWorks part. Should you request the replacement part or parts be sent via 'next day air', you will be charged the difference between ground service and 'next day air'.

It is hereby understood that engines, motors, pumps, or other components purchased by ThorWorks for use on its equipment are not warranted by ThorWorks and are sold only with the standard warranty of the manufacturer of that component. ThorWorks will send the returned component back to the respective manufacturer for evaluation. Should the manufacturer deny the warranty claim, then ThorWorks will not honor any warranty and you will be required to pay ThorWorks for the replacement item that was shipped to you.

Any claims for defective material or workmanship must be made prior to the expiration of thirty (30) days from the date the failure occurs, and in all cases prior to the expiration of the warranty period of one (1) year. It is the intent of this paragraph to limit ThorWorks liability solely to the cost of replacement parts, F.O.B. factory, or at the option of ThorWorks, to repair of the defective part or parts. No allowances for damages, lost revenues or lost time will be recognized.

This warranty is null and void if other than genuine ThorWorks parts are used. ThorWorks is constantly striving to improve their products. Changes in design and improvement will be made whenever the manufacturer believes the efficiency of the product will be improved, without incurring any obligation to incorporate such improvements in any machines which have been shipped or are in service.

In an effort to continue to improve product quality, ThorWorks reserves the right to change specifications without notice. Any modification or alteration of this machine without prior approval of the manufacturer may void the warranty.

CALIFORNIA

Proposition 65 Warning

Diesel engine exhaust and some of its constituents are known to the State of California to cause cancer, birth defects, and other reproductive harm.

TABLE OF CONTENTS

WARRANTY	PG.1
TANK DEPTH CHART	PG.2
OPERATION	PG.3-4
PARTS LIST-SCHEMATICS	PG.5-12
TATTLETALE SWITCH TROUBLESHOOTING	PG.13
ENGINE MANUAL	PG.14-42
OIL MSDS	PG.43-46

TANK CHART FOR SP575

MATERIAL DEPTH INCHES	GALLONS	MATERIAL DEPTH INCHES	GALLONS
48	580	24	290
47	577	23	274
46	571	22	259
45	565	21	244
44	557	20	229
43	548	19	214
42	538	18	199
41	527	17	184
40	516	16	169
39	504	15	155
38	492	14	141
37	479	13	127
36	466	12	113
35	453	11	100
34	439	10	87
33	425	9	75
32	411	8	63
31	396	7	52
30	381	6	42
29	366	5	32
28	351	4	23
27	336	3	15
26	321	2	8
25	305	1	3

BEFORE STARTING ENGINE

1. Check the fluid levels.
2. Make certain the forward-reverse control lever (1) is in the neutral position.
3. All hydraulic valve handles (7-8-9) should be in the neutral position.

STARTING PROCEDURE

1. Push the throttle lever (2) about 1/3 of the way up.
2. Turn the key (12) all the way to the left position to activate the engine glow plugs for about 5 seconds, or until the glow plug lamp (6) goes off.
3. Depress and hold the red push button (3) located to the left of the steering wheel, and turn the key all the way to the right. Once the engine starts and gets up to speed, release the red push button.
4. If the engine does not stay running, repeat the procedure. If after three attempts the engine will not stay running, then check the engine oil level and coolant levels. It is possible one of these sensors has failed. Refer to the trouble-shooting guide found later in this manual.

OPERATION

1. To move the machine forward, slowly push forward on the forward reverse lever (1). To go into reverse, bring the lever back to neutral, completely stopping before going into reverse.

ALWAYS STOP COMPLETELY BEFORE CHANGING DIRECTIONS!

2. Place the desired amount of material in the tank, add water, additives. Engage the agitator control (7) to the desired position. Speed control is achieved by turning a knob located on the side of the agitator drive motor (21). Turn clockwise to rotate faster. **SLOWLY** add your sand in the center of the tank. Let the agitator mix in each bag before adding another.
3. With the machine at your starting point, using valve (9) lower the squeegee assembly. Push with your toes on each foot peddles. This will open the dump valves (16), with the

box full of product start the machine in motion. Keep the box full of product by regulating the foot valves.

4.If the lot is sloped you can close the lower valve to help keep material from overflowing the box. The rear squeegee can be angled left or right by using valve (8). This allows for a 'wet edge' on long pulls. The wet edge aids in reducing line marks.

5.During very hot weather a better adhesion of sealer to blacktop can be obtained by use of the water fogging nozzle. Water spray will cool the surface slightly helping the sealer from being 'cooked' by the super hot surface temperature.

6.On the operators panel is a switch (10) and a pushbutton (11).Both are used to operate the water pump. First, move the toggle switch (10) to the on position, then press the pushbutton (11),holding it in for a few seconds. This will allow the pump to come on and spray thru the fogging nozzle located over the front tire.

7.Water will continue to flow till you shut off the toggle switch or the tanks run out of water. The water pump (29) has a pressure safety switch on it that will shut off the pump when the tank is empty. This keeps from overheating the pump impeller.

MAINTENANCE

1.Change the squeegee rubbers on an as needed basis.

2.Change the hydraulic oil filters yearly and the oil every two years, or sooner if it becomes contaminated. Use a grade 68,viscosity 352 @ 100°F SUS hydraulic oil.

3.Follow the engine manuals recommendations for type of oil and frequency of changes.

4.Agitator shaft bearings should be greased monthly. Change the shaft seals at the first indication of leaking.

5.All lug nuts and wheel bolts need to have a torque setting of 90 lbs.ft.

6.Once a season tighten the setscrews in the coupler that joins the steering motor to the steering fork shaft.

7.The rubber wipers on the agitator blades are adjustable. Loosen the bolts and slide the rubber strip towards the tank wall so that it just touches. Re-tighten the bolts.

PARTS LIST

REF #	ITEM	PART #	QTY
1	FORWARD - REVERSE CONTROL	P488A002	1
	CABLE	P488A015	1
2	THROTTLE CONTROL	P488A009	1
3	TATTLE TALE SWITCH	P458B029	1
4	STEERING WHEEL	P496A002	1
	STEERING COLUMN	P473A001	1
	STEERING CONTROL	P936A001	1
5	HOUR METER	P991A001	1
6	ENGINE SYSTEMS GAUGE	P458B091	1
7	AGITATOR CONTROL VALVE	P472A019	1
8	SQUEEGEE ANGLE VALVE	P472A019	1
9	SQUEEGEE UP - DOWN VALVE	P472A019	1
10	TOGGLE SWITCH - WATER PUMP	P443A001	1
11	PUSH BUTTON - WATER PUMP	P916A001	1
12	ENGINE KEY SWITCH	P458B030	1
13	HYDRAULIC LIFT CYLINDER	P600A005	1
14	SHAFT BEARING	P434A004	2
15	SHAFT SEAL	P50137B007	2
16	3" BUTTERFLY VALVE	P398A009	2
17	TIRE	P576A007	3
	RIM	P577A007	3
18	HYDRAULIC DRIVE MOTOR	P474A059	2
19	SQUEEGEE ASSEMBLY	P70023C	1
	FRONT RUBBER	P459A003	1
	MIDDLE RUBBER	P459A003	1
	REAR RUBBER	P459A024	1
20	HYDRAULIC CYLINDER	P600A005	1

PARTS LIST

REF #	ITEM	PART #	QTY
21	HYDRAULIC AGITATOR MOTOR SPEED CONTROL	P474A061	1 1
22	SEAT	P602A003	1
23	LID LATCH	P953A003	1
24	SUCTION LINE FILTER FILTER HEAD	P908A005 P909A003	1 1
25	DIESEL ENGINE	P458A058	1
26	HYDRAULIC OIL COOLER	P716A003	1
27	HYDRAULIC STEERING MOTOR SHAFT COUPLER	P474A004 P498A004	1 1
28	FRONT DRIVE MOTOR - BRAKE	P474A060	1
29	WATER TANK 12 VOLT WATER PUMP PRESSURE SWITCH	P596A001 P593A001 P916A001	2 1 1
30	WHEEL HUB	P578A014	1
31	STEERING BEARING	P476A004	2
32	STEERING BEARING RACE	P476A005	2
33	HYDROSTATIC TRANSMISSION	P707A010	1
34	GEAR PUMP	P601A020	1
35	BRAKE CONTROL VALVE	P693A011	1
36	WHEEL MOTOR RELIEF VALVE	P693A003	1
37	FLOW DIVIDER VALVE	P700A003	1
38	RETURN LINE FILTER FILTER HEAD	P908A003 P909A002	1 1

PARTS LIST

REF #	ITEM	PART #	QTY
NS	WATER SPRAY NOZZLE	P449A025	1
NS	WHEEL LUG BOLTS	P579A002	6
NS	HYDRAULIC TANK BREATHER	P1050A006	1
NS	DIESEL TANK CAP	P464A002	1

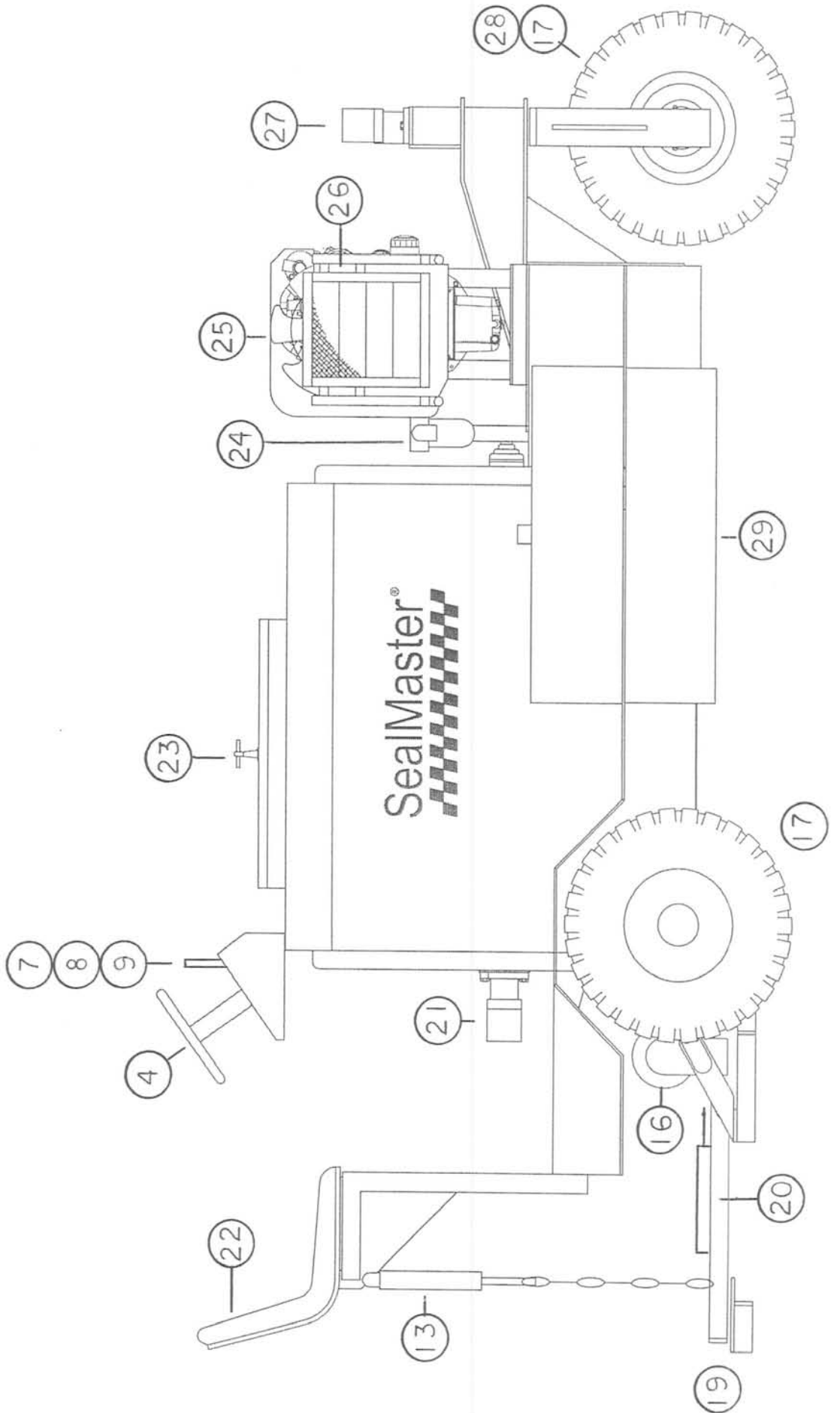

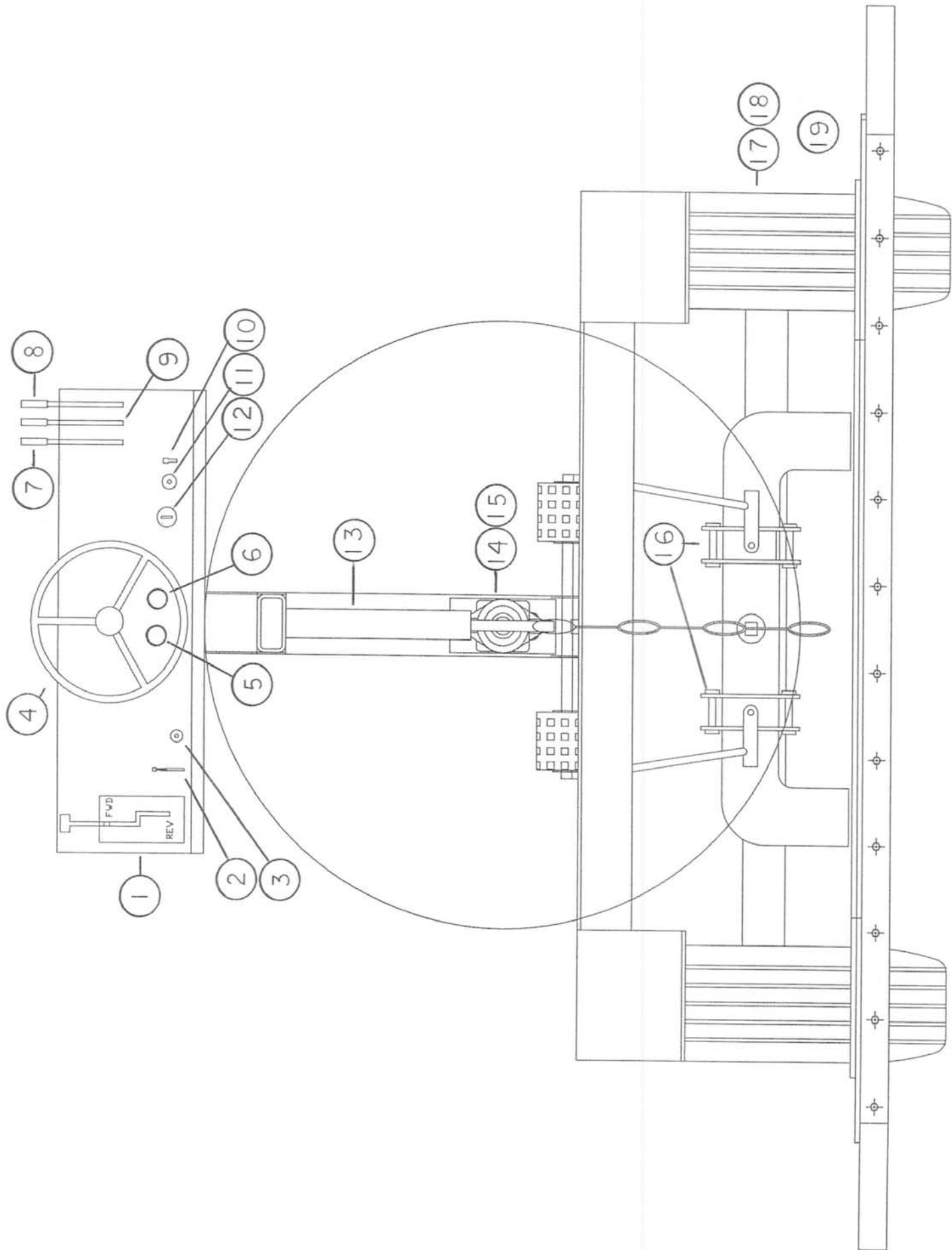

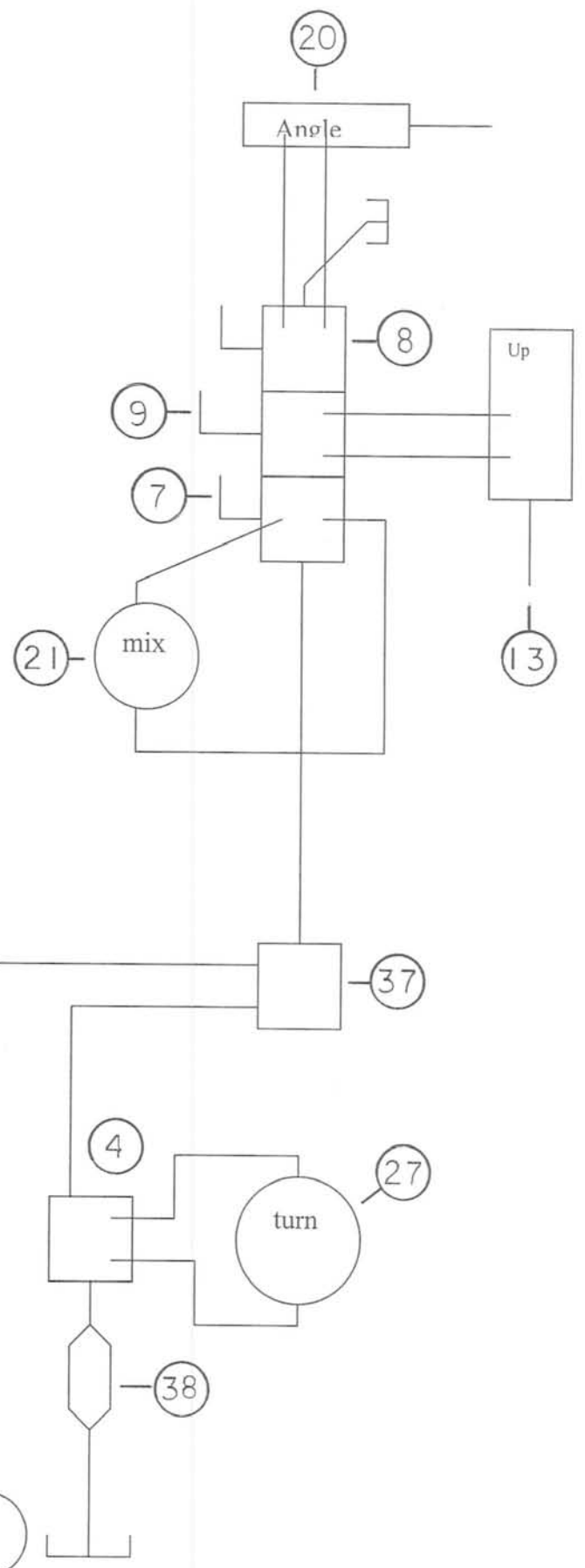
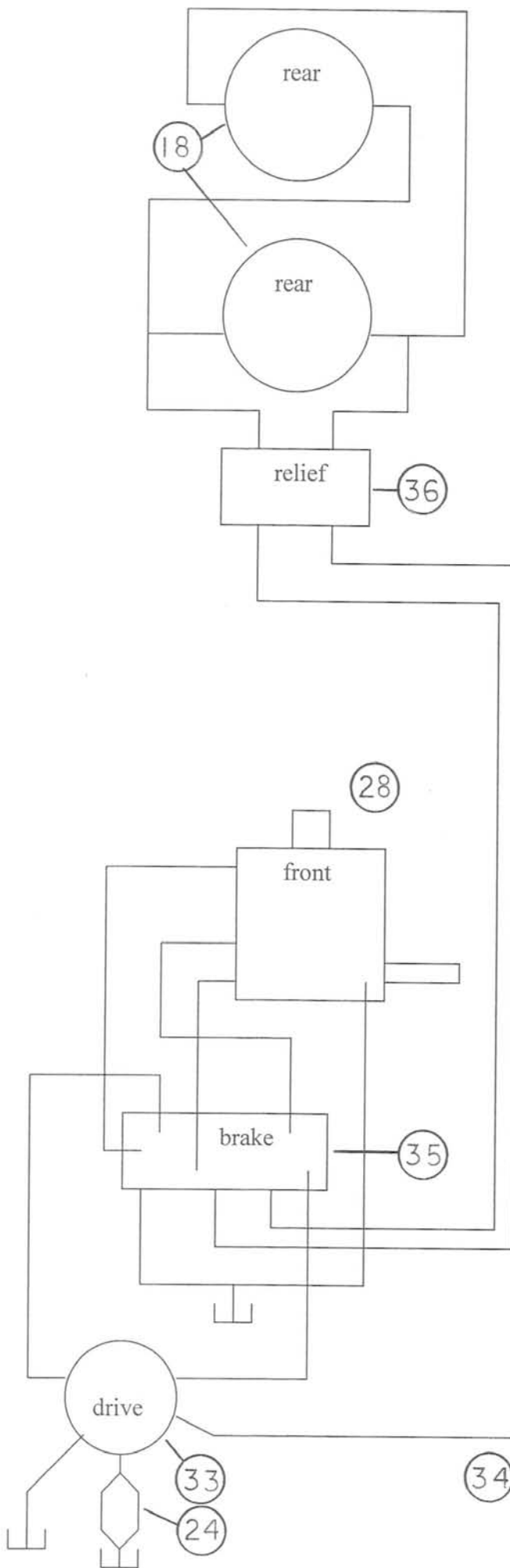

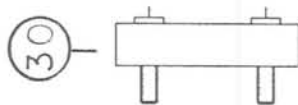
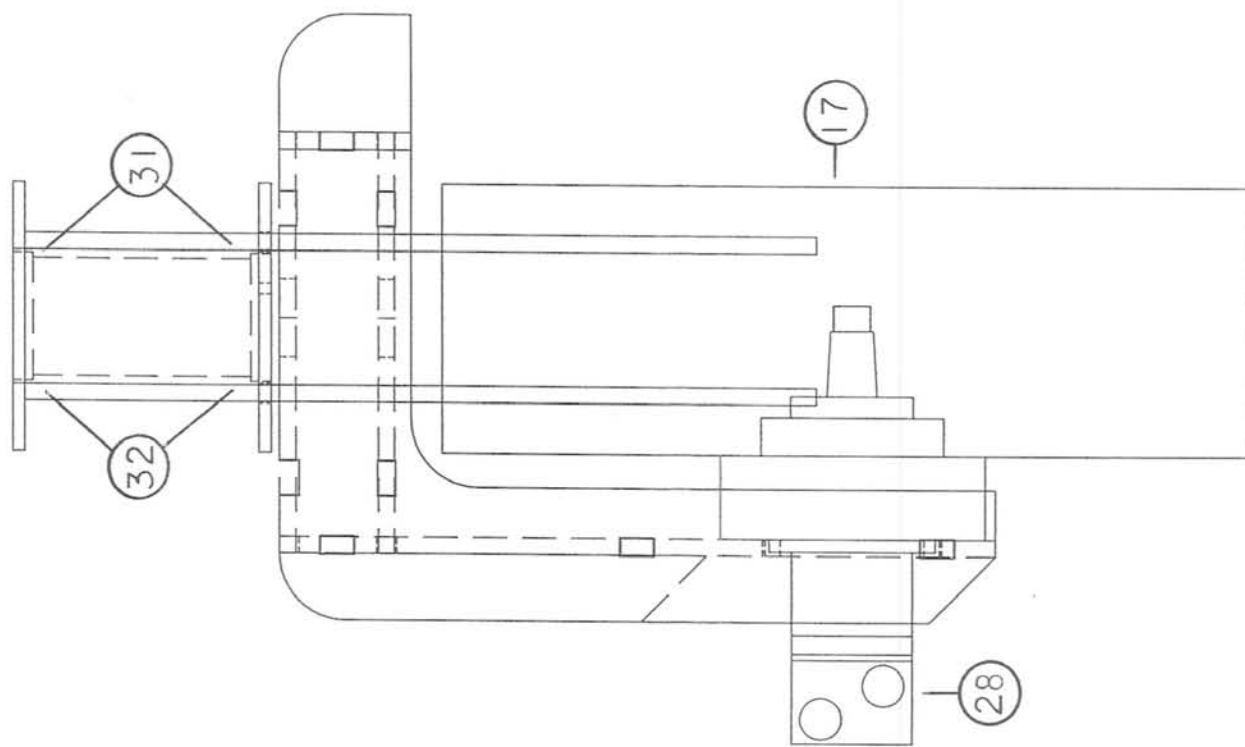

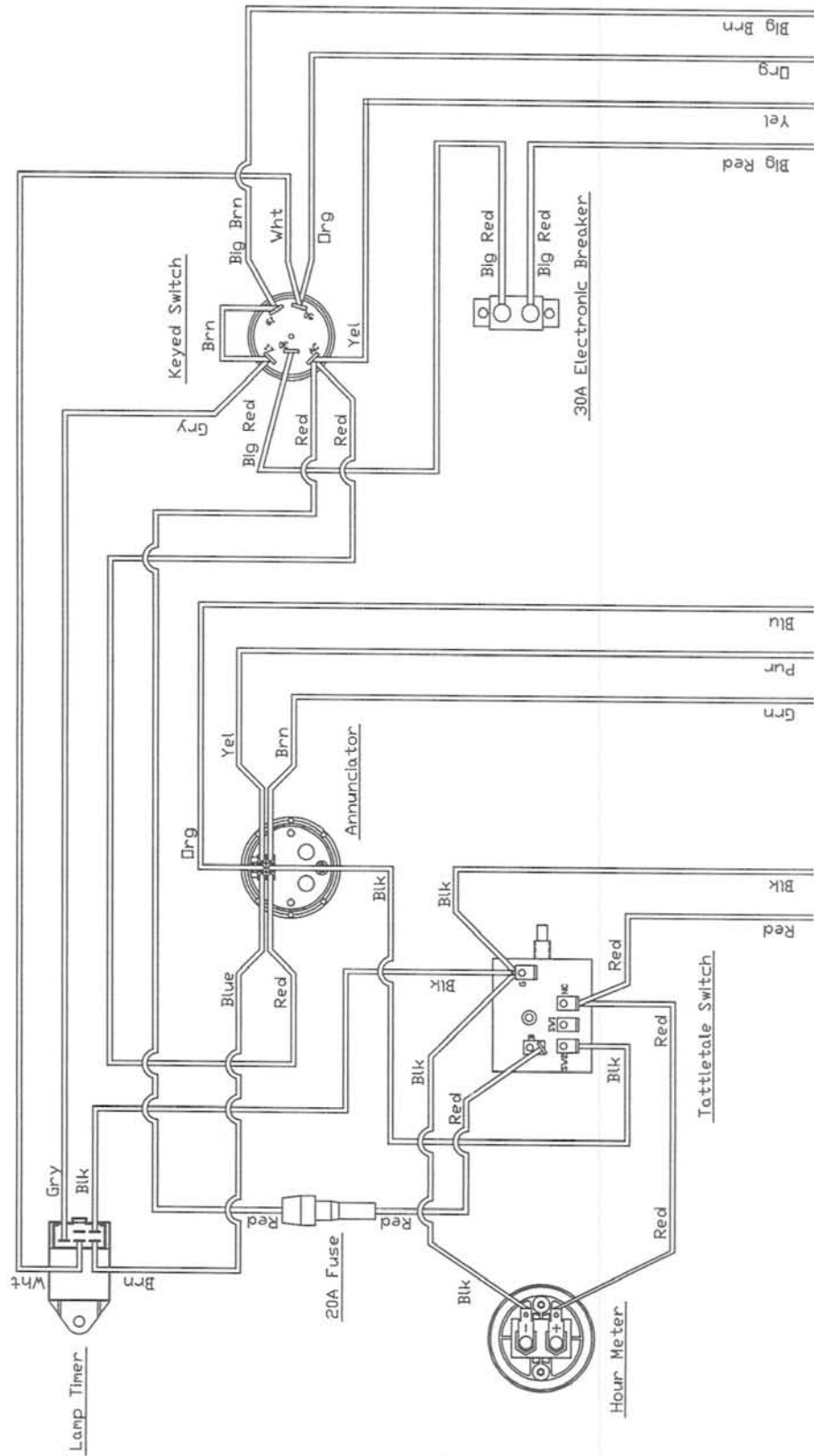

Pink - Fuel Pump (white)
 Gray - Tach

TYPICAL WIRING DIAGRAMS

Figure 1 shows a jumper installed between "SW1 and "SW2". SWICHGAGE® instruments are normally open. This is not a Closed Loop™ circuit.

Figure 1

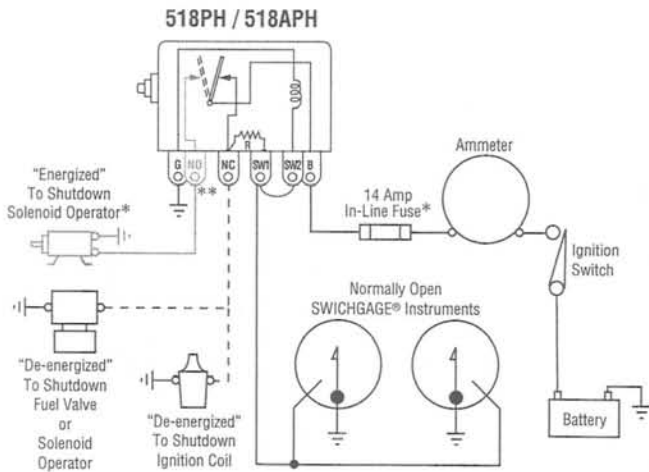

* In-Line Fuse should be removed on "energized" to shutdown configurations.

** Applies to 518APH model.

Figure 2 shows a Closed Loop™ circuit with normally open Murphy SWICHGAGE® instruments and Normally Closed switches (alignment and "V" belt switches, etc.).

Figure 2

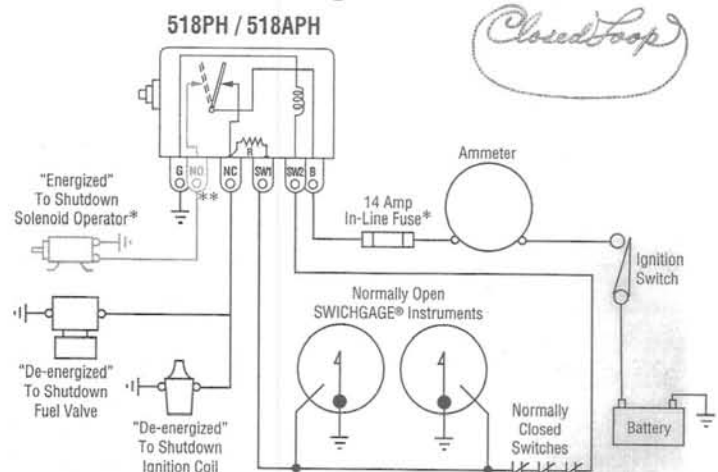

* In-Line Fuse should be removed on "energized" to shutdown configurations.

** Applies to 518APH model.

TROUBLESHOOTING

Push button will not remain in the depressed position after engine startup (wired according to Figure 2).

- Be sure oil pressure is adequate to raise pointer past SWICHGAGE® contact. (Not necessary if oil pressure SWICHGAGE® is equipped with push button lockout.)
- Visually check wiring for loose connections, frayed wiring, etc. on all terminals and within switch loop circuit.
- Check 14 amp fuse connected to "B" terminal.
- Check for good ground on "G" terminal.
- Disconnect switch loop circuit from "SW1" and "SW2" terminals. Place a temporary jumper between SW1 and SW2 and restart engine. If the push button stays in with engine running, the 518PH/518APH is not the problem. This indicates either an open circuit, unwanted ground, or too high resistance in switch loop circuit wiring between "SW1" and "SW2".
- Verify continuity by performing the following:
 1. Disconnect switch loop circuit from "SW1" and "SW2" terminals.
 2. Remove power from "B" terminal.
 3. Use an ohmmeter to check for "good continuity" (25 ohms or less) through switch loop circuit. If good continuity is indicated, proceed to Step 4.
 4. Adjust SWICHGAGE® contact away from pointer. Check continuity between one end of loop circuit, "SW1 or "SW2" and ground. Good

continuity (25 ohms or less) indicates an unwanted ground in loop circuit such as a terminal rotating against the mounting panel. Remove ground, restore loop circuit connections to "SW1" and "SW2".

5. Reconnect power to "B" terminal and restart engine.

6. Using an ohmmeter, check resistance between one end of the loop circuit to the other. Resistance should not exceed 25 ohms. If resistance is too high, check for loose connections in loop circuit. Otherwise select larger size wire for loop circuit.

Engine fails to shutdown when contacts close on one-wire to ground SWICHGAGE® controls (wired according to Figure 1).

With engine running, jumper "SW1" to "G" terminal. If switch trips and engine shuts down, trouble could be SWICHGAGE® contacts not making contact, lack of good case ground on SWICHGAGE®, or broken/cut wire.

Lack of case ground on SWICHGAGE®.

Verify that mounting bracket on the SWICHGAGE® has broken through the panel paint and has made good contact with bare metal. If good contact has not been made, tighten mounting stud nuts accordingly.

Failure of contacts on SWICHGAGE® to make contact.

Adjust contacts back and forth against the pointer to give a wiping and cleaning action on contacts. If this does not correct the problem, replace SWICHGAGE®.

MURPHY

FW Murphy

P.O. Box 470248

Tulsa, Oklahoma 74147 USA

+1 918 317 4100 fax +1 918 317 4266

e-mail sales@fwmurphy.com

www.fwmurphy.com

CONTROL SYSTEMS & SERVICES DIVISION

P.O. Box 1819; Rosenberg, Texas 77471; USA

+1 281 633 4500 fax +1 281 633 4588

e-mail sales@fwmurphy.com

MURPHY DE MEXICO, S.A. DE C.V.

Blvd. Antonio Rocha Cordero 300, Fracción del Aguaje

San Luis Potosí, S.L.P.; México 78384

+52 444 8206264 fax +52 444 8206336

Villahermosa Office +52 993 3162117

e-mail ventas@murphymex.com.mx

www.murphymex.com.mx

INDUSTRIAL PANEL DIVISION

P.O. Box 470248

Tulsa, Oklahoma 74147 USA

+1 918 317 4100 fax +1 918 317 4266

e-mail sales@fwmurphy.com

www.fwmurphy.com

FRANK W. MURPHY, LTD.

Church Rd.; Laverstock, Salisbury SP1 1QZ; U.K.

+44 1722 410055 fax +44 1722 410088

e-mail sales@fwmurphy.co.uk

www.fwmurphy.co.uk



USA-ISO 9001:2000 FM 18221

UK-ISO 9001:2000 FM 18422

Printed in U.S.A.

In order to consistently bring you the highest quality, full featured products, we reserve the right to change our specifications and designs at any time.

**OPERATOR'S MANUAL
KUBOTA DIESEL ENGINE**

**MANUEL DE L'OPERATEUR
MOTEUR DIESEL DE KUBOTA**

**BEDIENUNGSANLEITUNG
KUBOTA DIESEL MOTOR**

**MANUALE DELL'OPERATORE
KUBOTA MOTORE DIESEL**

**MANUAL DEL OPERADOR
MOTOR DIESEL KUBOTA**

**D905-E·D1105-TE·V1305-E
D1005-E·V1205-E·V1505-E
D1105-E·V1205-TE·V1505-TE**

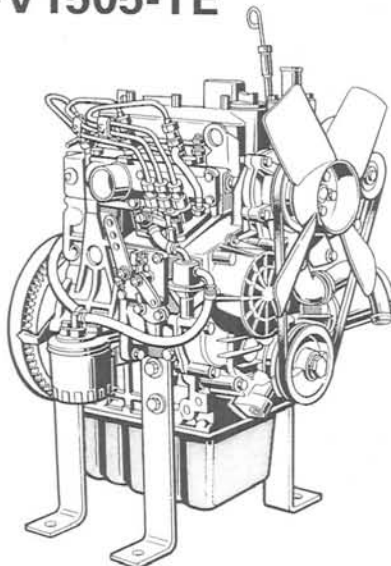

D-2107

*READ AND SAVE THIS BOOK
MANUEL A LIRE ET A CONSERVER
DIESE ANLEITUNG SORGFÄLTIG DURCHLESEN
UND GRIFFBEREIT AUFBEWAHREN
LEGGETE E CONSERVATE QUESTO MANUALE
LEAN Y CONSERVEN ESTE MANUAL*

Kubota

SERVICING OF THE ENGINE

Your dealer is interested in your new engine and has the desire to help you get the most value from it. After reading this manual thoroughly, you will find that you can do some of the regular maintenance yourself. However, when in need of parts or major service, be sure to see your KUBOTA dealer.

For service, contact the KUBOTA Dealership from which you purchased your engine or your local KUBOTA dealer.

When in need of parts, be prepared to give your dealer the engine serial number.

Locate the serial number now and record them in the space provided.

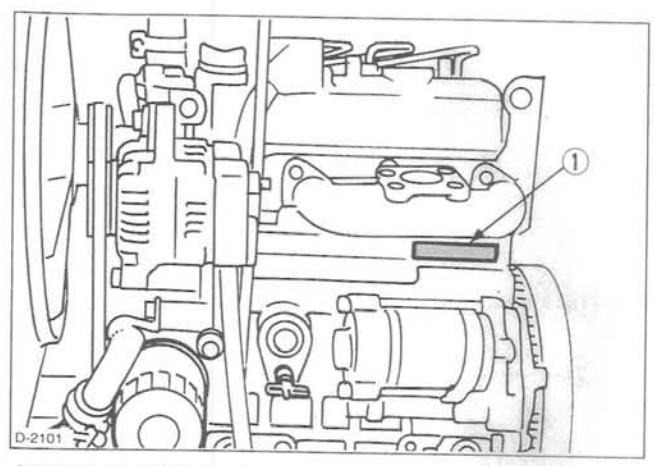

(1) Engine serial number

Type	Serial No.
Engine _____	_____
Date of Purchase _____	_____
Name of Dealer _____	_____
(To be filled in by purchaser)	

NAMES OF PARTS

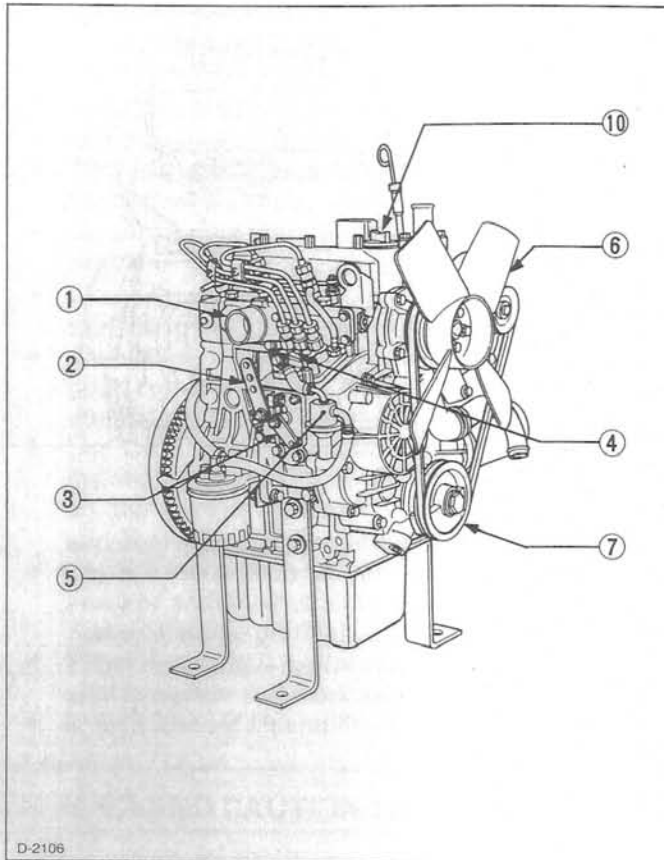

- (1) Intake manifold
- (2) Speed control lever
- (3) Engine stop lever
- (4) Injection pump
- (5) Fuel feed pump
- (6) Cooling fan
- (7) Fan drive pulley
- (8) Oil filter cartridge
- (9) Water drain cock

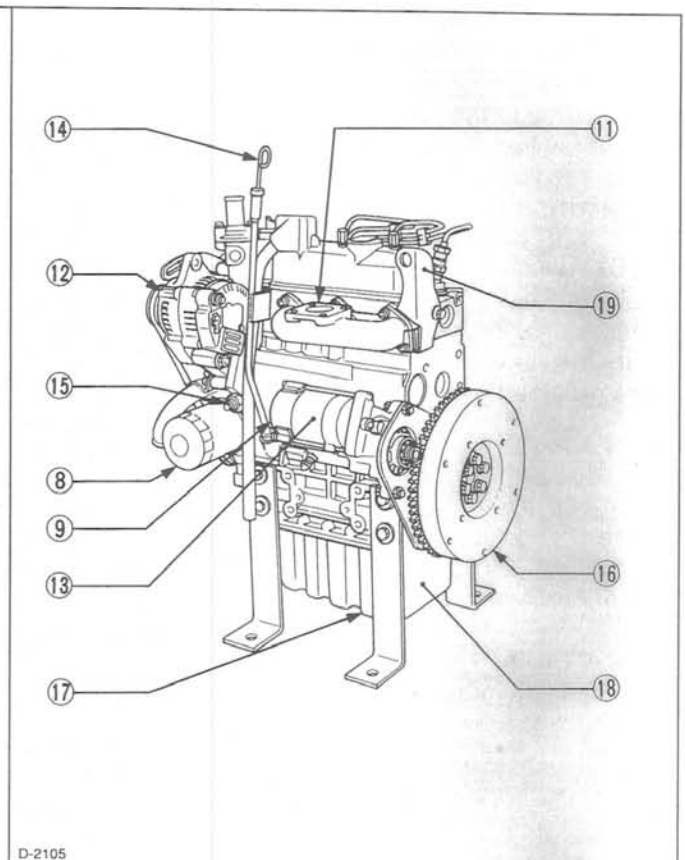

- (10) Oil filler plug
- (11) Exhaust manifold
- (12) Alternator
- (13) Starter
- (14) Oil level gauge
- (15) Oil pressure switch
- (16) Flywheel
- (17) Oil drain plug
- (18) Oil pan
- (19) Engine hook

PRE-OPERATION CHECK

BREAK-IN

During the engine break-in period, observe the following by all means:

1. Change engine oil and oil filter cartridge after the first 50 hours of operation (See "ENGINE OIL" in PERIODIC SERVICE Section).
2. When ambient temperature is low, operate the machine after the engine has been completely warmed up.

DAILY CHECK

To prevent trouble from occurring, it is important to know the conditions of the engine well. Check it before starting.



CAUTION

To avoid personal injury:

- Be sure to install shields and safeguards attached to the engine when operating.
- Stop the engine at a flat and wide space when checking.
- Keep dust or fuel away from the battery, wiring, muffler and engine to prevent a fire. Check and clear them before operating everyday. Pay attention to the heat of the exhaust pipe or exhaust gas so that it can not ignite trash.

Item		Ref. page
1. Parts which had trouble in previous operation.		-
2. By walking around the machine	(1) Oil or water leaks	13 to 18
	(2) Engine oil level and contamination	13, 14
	(3) Amount of fuel	10
	(4) Amount of coolant	15 to 18
	(5) Dust in air cleaner dust cup	19, 20
	(6) Damaged parts and loosened bolts and nuts	-
3. By inserting the key into the starter switch	(1) Proper functions of meters and pilot lamps; no stains on these parts	-
	(2) Proper functions of glow lamp timer	-
4. By starting the engine	(1) Color of exhaust fumes	7
	(2) Unusual engine noise	7

OPERATING THE ENGINE

STARTING THE ENGINE (NORMAL)



CAUTION

To avoid personal injury:

- Do not allow children to approach the machine while the engine is running.
- Be sure to install the machine on which the engine is installed, on a flat place.
- Do not run the engine on gradients.
- Do not run the engine in an enclosed area. Exhaust gas can cause air pollution and exhaust gas poisoning.
- Keep your hands away from rotating parts (such as fan, pulley, belt, flywheel etc.) during operation.
- Do not operate the machine while under the influence of alcohol or drugs.
- Do not wear loose, torn or bulky clothing around the machine. It may catch on moving parts or controls, leading to the risk of accident. Use additional safety items, e.g. hard hat, safety boots or shoes, eye and hearing protection, gloves, etc., as appropriate or required.
- Do not wear radio or music headphones while operating engine.
- Check to see if it is safe around the engine before starting.
- Reinstall safeguards and shields securely and clear all maintenance tools when starting the engine after maintenance.

IMPORTANT:

- Do not use ether or any starting fluid for starting the engine, or a severe damage will occur.
- When starting the engine after a long storage (of more than 3 months), first set the stop lever to the "STOP" position and then activate the starter for about 10 seconds to allow oil to reach every engine part.

1. Set the fuel lever to "ON".

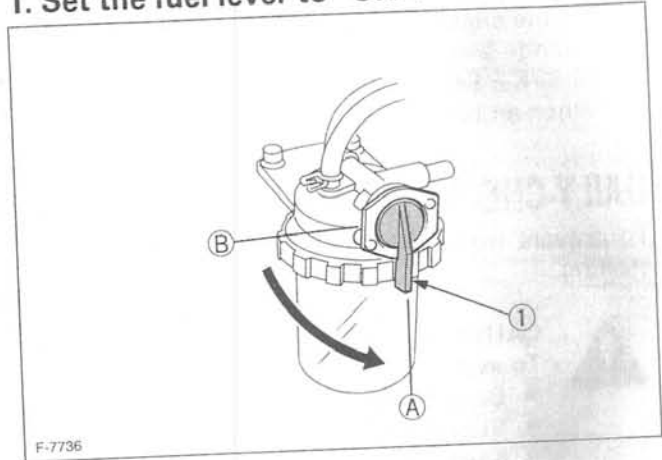

(1) Fuel lever

(A) "ON"

(B) "OFF"

2. Place the engine stop lever in the "START" position.

3. Place the speed control lever at more than half "OPERATION".

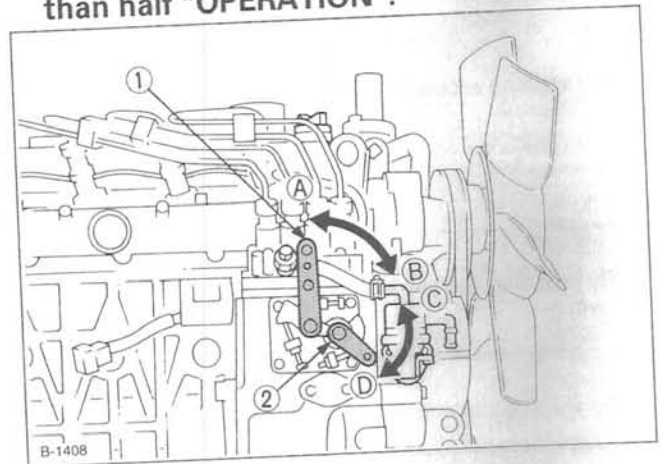

(1) Speed control lever

(2) Engine stop lever

(A) "IDLING"

(B) "OPERATION"

(C) "START"

(D) "STOP"

- Insert the key into the key switch and turn it "ON".

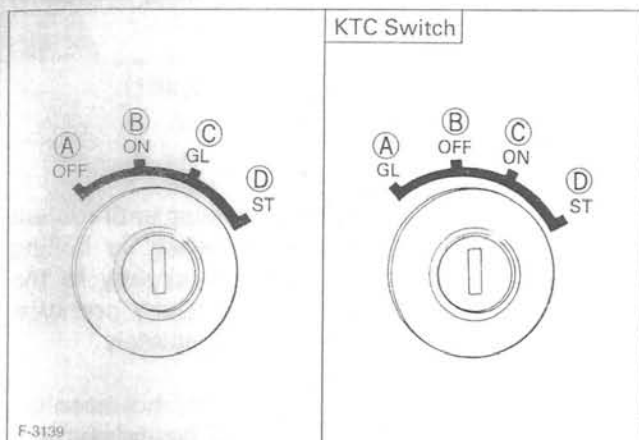

- | | |
|--------------------|--------------------|
| (A) "SWITCHED OFF" | (A) "PREHEATING" |
| (B) "OPERATION" | (B) "SWITCHED OFF" |
| (C) "PREHEATING" | (C) "OPERATION" |
| (D) "STARTING" | (D) "STARTING" |

- Turn the starter switch to the "PREHEATING" position to allow the glow lamp to redden.
- Turn the key to the "STARTING" position and the engine should start. Release the key immediately when the engine starts.
- Check to see that the oil pressure lamp and charge lamp are off. If the lamps are still on, immediately stop the engine, and determine the cause.
(See "CHECKS DURING OPERATION" in OPERATING THE ENGINE Section)

NOTE:

- If the oil pressure lamp should be still on, immediately stop the engine and check;
 - if there is enough engine oil.
 - if the engine oil has dirt in it.
 - if the wiring is faulty.

- Warm up the engine at medium speed without load.

IMPORTANT:

- If the glow lamp should redden too quickly or too slowly, immediately ask your KUBOTA dealer to check and repair it.
- If the engine does not catch or start at 10 seconds after the starter switch is set at "STARTING", wait for another 30 seconds and then begin the engine starting sequence again. Do not allow the starter motor to run continuously for more than 20 seconds.

COLD WEATHER STARTING

If the ambient temperature is below* -5°C(23°F) and the engine is very cold, start it in the following manner:

Take steps (1) through (4) left.

- Turn the key to "PREHEATING(GLOW)" position and keep it there for a certain period mentioned below.

IMPORTANT:

- Shown below are the standard preheating times for various temperatures. This operation, however, is not required, when the engine is warmed up.

Ambient temperature	Preheating time	
	Ordinary heat type	With glow lamp timer
Above 10°C (50°F)	NO NEED	
10°C (50°F) to -5°C (23°F)	Approx. 5 seconds	See NOTE:
*Below -5°C (23°F)	Approx. 10 seconds	
Limit of continuous use	20 seconds	

NOTE:

- In case of installing standard glow lamp, glow lamp goes off after about 6 seconds, when the starter switch key is turned to preheating position. However if necessary, keep the starter switch key at preheating position for longer time, according to the left recommendation.

- Turn the key to "ST (STARTING)" position and the engine should start.

(If the engine fails to start after 10 seconds, turn off the key for 5 to 30 seconds. Then repeat steps (5) and (6).)

IMPORTANT:

- Do not allow the starter motor to run continuously for more than 20 seconds.
- Be sure to warm up the engine, not only in winter, but also in warmer seasons. An insufficiently warmed-up engine can shorten its service life.
- When there is a fear of temperature dropping below -15°C (5°F), detach the battery from the machine, and keep it indoors in a safe area to be reinstalled just before the next operation.

STOPPING THE ENGINE

1. Return the speed control lever to low idle, and run the engine under idling conditions.
2. Set the engine stop lever to the "STOP" position.
3. With the starter switch placed at the "OFF" position, remove the key. (Be sure to return the engine stop lever to the "START" position to be ready for the next start.)

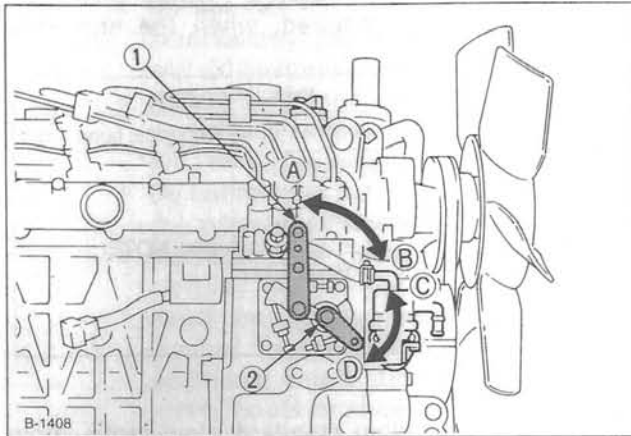

- | | |
|-------------------------|-----------------|
| (1) Speed control lever | (A) "IDLING" |
| (2) Engine stop lever | (B) "OPERATION" |
| | (C) "START" |
| | (D) "STOP" |

IMPORTANT

- If equipped with a turbo-charger, allow the engine to idle for 5 minutes before shutting it off after a full load operation. Failure to do so may lead to turbo-charger trouble.

CHECKS DURING OPERATION

While running, make the following checks to see that all parts are working correctly.

■ Radiator Cooling water (Coolant)



WARNING

To avoid personal injury:

- Do not remove radiator cap until coolant temperature is well below its boiling point. Then loosen cap slightly to the stop position, to relieve any pressure, before removing cap completely.

When the engine overheats and hot coolant overflows through the radiator and hoses, stop the engine immediately and make the following checks to determine the cause of trouble:

Check item

1. Check to see if there is any coolant leak;
2. Check to see if there is any obstacle around the cooling air inlet or outlet;
3. Check to see if there is any dirt or dust between radiator fins and tube;
4. Check to see if the fan belt is too loose;
5. Check to see if radiator water pipe is clogged; and
6. Check to see if anti-freeze is mixed to a 50/50% mix of water and anti-freeze.

■ Oil pressure lamp

The lamp lights up to warn the operator that the engine oil pressure has dropped below the prescribed level. If this should happen during operation or should not go off even after the engine is accelerated more than 1000rpm, immediately stop the engine and check the following:

1. Engine oil level (See "ENGINE OIL" in MAINTENANCE Section).
2. Lubricant system (See "ENGINE OIL" in MAINTENANCE Section).

■ Fuel



CAUTION

To avoid personal injury:

- Fluid escaping from pinholes may be invisible. Do not use hands to search for suspected leaks; Use a piece of cardboard or wood, instead. If injured by escaping fluid, see a medical doctor at once. This fluid can produce gangrene or a severe allergic reaction.
- Check any leaks from fuel pipes or fuel injection pipes. Use eye protection when checking for leaks.

Be careful not to empty the fuel tank. Otherwise air may enter the fuel system, requiring fuel system bleeding. (See "FUEL" in MAINTENANCE Section).

■ Color of exhaust

While the engine is run within the rated output range:

- The color of exhaust remains colorless.
- If the output slightly exceeds the rated level, exhaust may become a little colored with the output level kept constant.
- If the engine is run continuously with dark exhaust emission, it may lead to trouble with the engine.

■ Immediately stop the engine if;

- The engine suddenly slow down or accelerates.
- Unusual noises suddenly appear.
- Exhaust fumes suddenly become very dark.
- The oil pressure lamp or the water temperature alarm lamp lights up.

REVERSED ENGINE REVOLUTION AND REMEDIES



CAUTION

To avoid personal injury:

- Reversed engine operation can make the machine reverse and run it backwards. It may lead to serious trouble.
- Reversed engine operation may make exhaust gas gush out into the intake side and ignite the air cleaner; It could catch fire.

Reversed engine revolution must be stopped immediately since engine oil circulation is cut quickly, leading to serious trouble.

■ How to tell when the engine starts running backwards

1. Lubricating oil pressure drops sharply. Oil pressure warning light, if used, will light.
2. Since the intake and exhaust sides are reversed, the sound of the engine changes, and exhaust gas will come out of the air cleaner.
3. A louder knocking sound will be heard when the engine starts running backwards.

■ Remedies

1. Immediately set the engine stop lever to the "STOP" position to stop the engine.
2. After stopping the engine, check the air cleaner, intake rubber tube and other parts and replace parts as needed.

MAINTENANCE



CAUTION

To avoid personal injury:

- Be sure to conduct daily checks, periodic maintenance, refueling or cleaning on a level surface with the engine shut off and remove the key.
- Before allowing other people to use your engine, explain how to operate, and have them read this manual before operation.
- When cleaning any parts, do not use gasoline but use regular cleanser.
- Always use proper tools, that are in good condition. Make sure you understand how to use them, before performing any service work.
- When installing, be sure to tighten all bolts lest they should be loose. Tighten the bolts by the specified torque.
- Do not put any tools on the battery, or battery terminals may short out. Severe burns or fire could result. Detach the battery from the engine before maintenance.
- Do not touch muffler or exhaust pipes while they are hot; Severe burns could result.

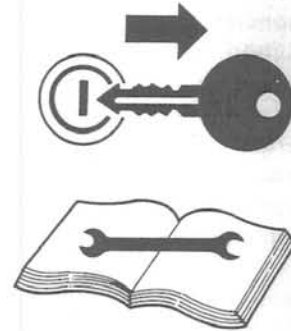

B-1509



B-1497

SERVICE INTERVALS

Observe the following for service and maintenance.

The lubricating oil change intervals listed in the table below are for Classes CF, CE and CD lubricating oils of API classification with a low-sulfur fuel in use. If the CF-4 or CG-4 lubricating oil is used with a high-sulfur fuel, change the lubricating oil at shorter intervals than recommended in the table below depending on the operating condition.

Interval	Item	Ref. Page		
Every 50 hours	Check of fuel pipes and clamp bands	12		@
See NOTE:	Change of engine oil	13, 14	⊙	
Every 100 hours	Cleaning of air cleaner element	19, 20	*1	@
	Cleaning of fuel filter	12		
	Check of battery electrolyte level	20		
	Check of fan belt tightness	22		
Every 200 hours	Check of radiator hoses and clamp bands	17		
	Replacement of oil filter cartridge	15	⊙	
	Check of intake air line	—		@

Interval	Item	Ref. Page		
Every 400 hours	Replacement of fuel filter cartridge	13		@
Every 500 hours	Removal of sediment in fuel tank	—		
	Cleaning of water jacket (radiator interior)	15 to 18		
	Replacement of fan belt	22		
Every one or two months	Recharging of battery	20		
Every year	Replacement of air cleaner element	19, 20	*2	@
	Check of damage in electric wiring and loose connections	—		
Every 800 hours	Check of valve clearance	24		
Every 1500 hours	Check of fuel injection nozzle injection pressure	—	*3	@
Every 3000 hours	Check of turbo charger	—	*3	@
	Check of injection pump	—	*3	@
	Check of fuel injection timer	—	*3	@
Every two years	Change of radiator coolant (L.L.C.)	17		
	Replacement of battery	20		
	Replacement of radiator hoses and clamp bands	18		
	Replacement of fuel pipes and clamp bands	12	*3	@
	Replacement of intake air line	—	*4	@

IMPORTANT

- The jobs indicated by © must be done after the first 50 hours of operation.
- *1 Air cleaner should be cleaned more often in dusty conditions than in normal conditions.
- *2 After 6 times of cleaning.
- *3 Consult your local KUBOTA Dealer for this service.
- *4 Replace only if necessary.
- When the battery is used for less than 100 hours in a year, check its electrolyte yearly. (for refillable battery's only)
- The items listed above (@ marked) are registered as emission related critical parts by KUBOTA in the U.S. EPA nonroad emission regulation. As the engine owner, you are responsible for the performance of the required maintenance on the engine according to the above instruction.
Please see the Warranty Statement in detail.

NOTE:

- Changing interval of engine oil depends on the conditions below.

Models	Oil pan depth	
	Above 125 mm (4.9 in.)	※below 101 mm (4.0 in.)
All models	200 Hrs	150 Hrs
Initial	50 Hrs	

- ※ 101mm oil pan depth is optional.
- ※※ Standard replacement interval
 - API service classification: above CD grade
 - Ambient temperature: below 35 °C (95 °F)

NOTE:**Lubricating oil**

With the emission control now in effect, the CF-4 and CG-4 lubricating oils have been developed for use of a low-sulfur fuel on on-road vehicle engines. When an

off-road vehicle engine runs on a high-sulfur fuel, it is advisable to employ the CF, CD or CE lubricating oil with a high total base number. If the CF-4 or CG-4 lubricating oil is used with a high-sulfur fuel, change the lubricating oil at shorter intervals.

- **Lubricating oil recommended when a low-sulfur or high-sulfur fuel is employed.**

○ : Recommendable × : Not recommendable

Lubricating oil class	Fuel		Remarks
	Low sulfur	High sulfur	
CF	○	○	TBN ≥ 10
CF-4	○	×	
CG-4	○	×	

PERIODIC SERVICE

FUEL

Fuel is flammable and can be dangerous. You should handle fuel with care.



CAUTION

To avoid personal injury:

- Do not mix gasoline or alcohol with diesel fuel. This mixture can cause an explosion.
- Be careful not to spill fuel during refueling. If fuel should spill, wipe it off at once, or it may cause a fire.
- Do not fail to stop the engine before refueling. Keep the engine away from the fire.
- Be sure to stop the engine while refueling or bleeding and when cleaning or changing fuel filter or fuel pipes. Do not smoke when working around the battery or when refueling.
- Check the above fuel systems at a well ventilated and wide place.
- When fuel and lubricant are spilled, refuel after letting the engine cool off.
- Always keep spilled fuel and lubricant away from engine.

Fuel level check and refueling

1. Check to see that the fuel level is above the lower limit of the fuel level gauge.
2. If the fuel is too low, add fuel to the upper limit. Do not overfill.

No.2-D is a distillate fuel oil of lower volatility for engines in industrial and heavy mobile service.

(SAE J313 JUN87)

Grade of Diesel Fuel Oil According to ASTM D975

Flash Point, °C (°F)	Water and Sediment, volume %	Carbon Residue on, 10 percent Residuuum, %	Ash, weight %
Min	Max	Max	Max
52 (125)	0.05	0.35	0.01

Distillation Tempera- tures, °C (°F) 90% Point		Viscosity Kinematic cSt or mm ² /s at 40°C		Viscosity Sayboit, SUS at 100°F		Sulfur, weight %	Copper strip Corro- sion	Cetane Num- ber
Min	Max	Min	Max	Min	Max	Max	Max	Min
282 (540)	338 (640)	1.9	4.1	32.6	40.1	0.50	No.3	40

The cetane number is required not to be less than 45.

IMPORTANT:

- Be sure to use a strainer when filling the fuel tank, or dirt or sand in the fuel may cause trouble in the fuel injection pump.
- For fuel, always use diesel fuel. You are required not to use alternative fuel, because its quality is unknown or it may be inferior in quality. Kerosene, which is very low in cetane rating, adversely affects the engine. Diesel fuel differs in grades depending on the temperature.
- Be careful not to let the fuel tank become empty, or air can enter the fuel system, necessitating bleeding before next engine start.

■ Air bleeding the fuel system



CAUTION

To avoid personal injury;

- Do not bleed a hot engine as this could cause fuel to spill onto a hot exhaust manifold creating a danger of fire.

Air bleeding of the fuel system is required if;

- after the fuel filter and pipes have been detached and refitted;
- after the fuel tank has become empty; or
- before the engine is to be used after a long storage.

[PROCEDURE (A)] (gravity feed fuel tanks only)

1. Fill the fuel tank to the fullest extent. Open the fuel filter lever.
2. Loosen air vent plug of the fuel filter a few turns.
3. Screw back the plug when bubbles do not come up any more.
4. Open the air vent plug on top of the fuel injection pump.
5. Retighten the plug when bubbles do not come up any more.

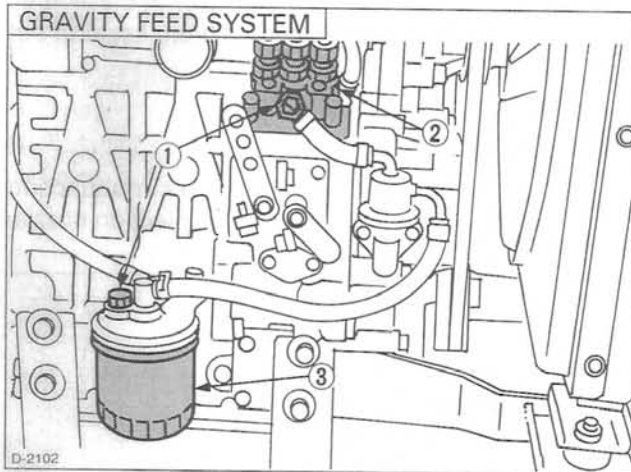

- (1) Air vent plug
- (2) Injection pump
- (3) Fuel filter

[PROCEDURE (B)]

(fuel tanks lower than injection pump)

1. For fuel tanks that are lower than the injection pump. The fuel system must be pressurized by the fuel system electric fuel pump.
2. If an electric fuel pump is not used, you must manually actuate the pump by lever to bleed.
3. The primary fuel filter (3) must be on the pressure side of the pump if the fuel tank is lower than the injection pump.
4. To bleed follow (2) through (5) above. (PROCEDURE (A))

IMPORTANT:

- Tighten air vent plug of the fuel injection pump except when bleeding, or it may stop the engine suddenly.

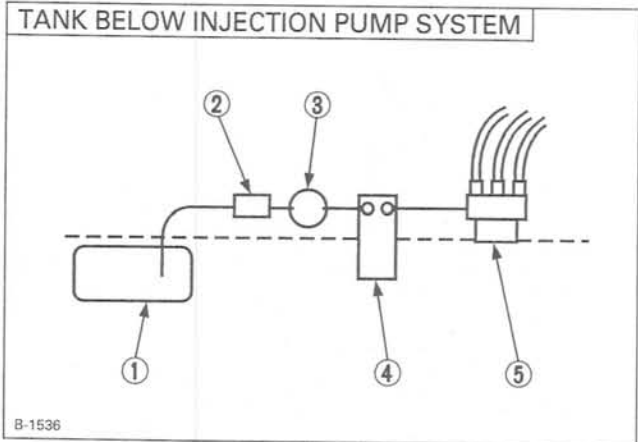

- (1) Fuel tank below injection pump
- (2) Pre-filter
- (3) Electric or Mechanical pump
- (4) Main Filter
- (5) Injection pump

Checking the fuel pipes



CAUTION

To avoid personal injury:

- Check or replace the fuel pipes after stopping the engine. Broken fuel pipes can cause fires.

Check the fuel pipes every 50 hours of operation. When if;

1. If the clamp band is loose, apply oil to the screw of the band, and tighten the band securely.
2. If the fuel pipes, made of rubber, become worn out, replace them and the clamp bands every two years.
3. If the fuel pipes and clamp bands are found worn or damaged before two years'time, replace or repair them at once.
4. After replacement of the pipes and bands, air-bleed the fuel system.

IMPORTANT:

- When the fuel pipes are not installed, plug them at both ends with clean cloth or paper to prevent dirt from entering. Dirt in the pipes can cause fuel injection pump malfunction.

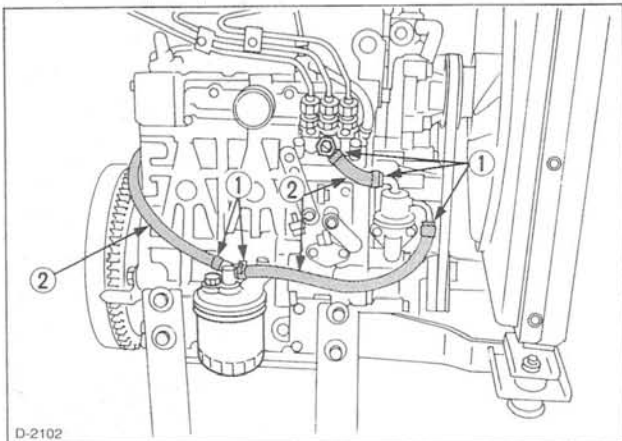

D-2102

- (1) Clamp band
- (2) Fuel pipe

Cleaning the fuel filter pot

Every 100 hours of operation, clean the fuel filter in a clean place to prevent dust intrusion.

1. Close the fuel filter lever.

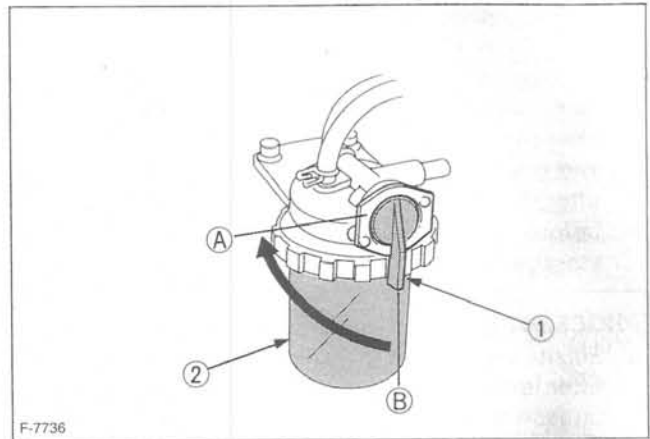

F-7736

- (1) Fuel filter lever (A) "OFF"
- (2) Fuel filter pot (B) "ON"

2. Remove the top cap, and rinse the inside with diesel fuel.
3. Take out the element, and rinse it with diesel fuel.
4. After cleaning, reinstall the fuel filter, keeping out of dust and dirt.
5. Air-bleed the injection pump.

IMPORTANT:

- Entrance of dust and dirt can cause a malfunction of the fuel injection pump and the injection nozzle. Wash the fuel filter cup periodically.

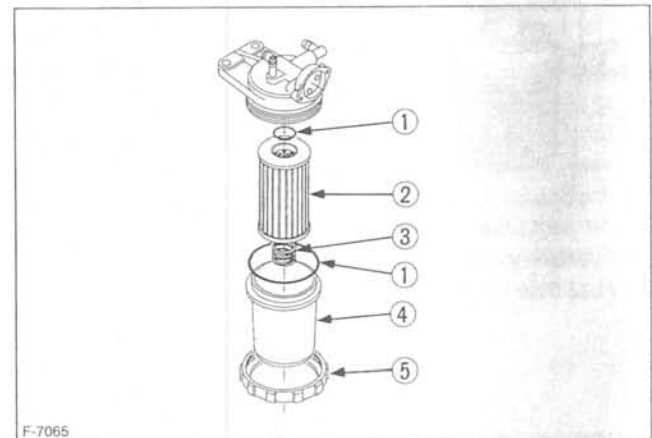

F-7065

- (1) O ring
- (2) Filter element
- (3) Spring
- (4) Filter bowl
- (5) Screw ring

Fuel filter cartridge replacement

1. Replace the fuel filter cartridge with a new one every 400 operating hours.
2. Apply fuel oil thinly over the gasket and tighten the cartridge into position by hand-tightening only.
3. Finally, vent the air.

IMPORTANT:

- Replace the fuel filter cartridge periodically to prevent wear of the fuel injection pump plunger or the injection nozzle, due to dirt in the fuel.

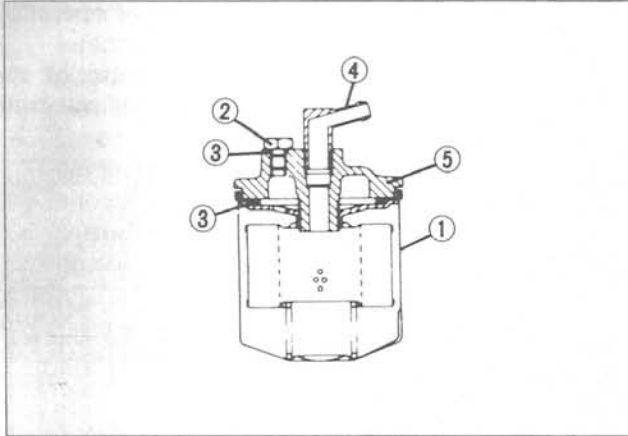

- (1) Fuel filter cartridge
 (2) Air vent plug
 (3) O ring
 (4) Pipe joint
 (5) Cover

ENGINE OIL



CAUTION

To avoid personal injury:

- Be sure to stop the engine before checking and changing the engine oil and the oil filter cartridge.
- Do not touch muffler or exhaust pipes while they are hot; Severe burns could result. Always stop the engine and allow it to cool before conducting inspections, maintenance, or for a cleaning procedure.
- Contact with engine oil can damage your skin.

Put on gloves when using engine oil. If you come in contact with engine oil, wash it off immediately.

NOTE:

- Be sure to inspect the engine, locating it on a level place. If placed on gradients accurately, oil quantity may not be measured.

Checking oil level and adding engine oil

1. Check the engine oil level before starting or more than 5 minutes after stopping the engine.
2. Remove the oil level gauge, wipe it clean and reinstall it.
3. Take the oil level gauge out again, and check the oil level.

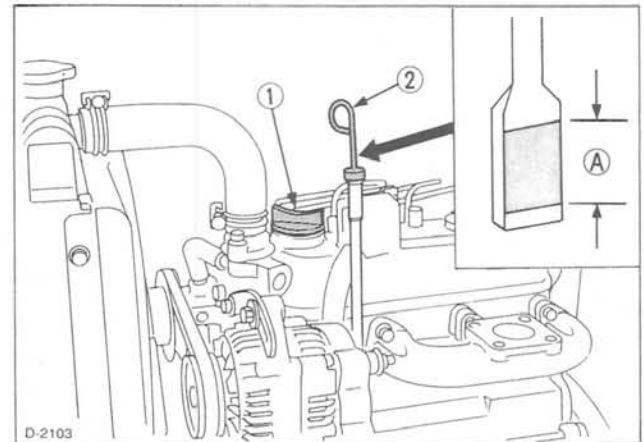

- (1) Oil filler plug
 (2) Oil level gauge

[Lower end of oil level gauge]
 (A) Engine oil level within this range is proper.

4. If the oil level is too low, remove the oil filler plug, and add new oil to the prescribed level.
5. After adding oil, wait more than 5 minutes and check the oil level again. It takes some time for the oil to drain down to the oil pan.

Engine oil quantity

Model	Quantity
D905-E, D1005-E, D1105-E, D1105-TE	5.1 L (1.35 U.S.gals.)
V1205-E, V1305-E, V1505-E	6.0 L (1.59 U.S.gals.)
V1205-TE, V1505-TE	6.7 L (1.77 U.S.gals.)

Oil quantities shown are for standard oil pans.

IMPORTANT:

- Engine oil should be MIL-L-2104C or have properties of API classification CD grades or higher.

Change the type of engine oil according to the ambient temperature.

above 25°C (77°F)	SAE30 or SAE10W-30 SAE10W-40
0 to 25°C (32 to 77°F)	SAE20 or SAE10W-30 SAE10W-40
below 0°C (32°F)	SAE10W or SAE10W-30 SAE10W-40

- When using oil of different brands from the previous one, be sure to drain all the previous oil before adding the new engine oil.

Changing engine oil**CAUTION**

To avoid personal injury:

- Be sure to stop the engine before draining engine oil.
- When draining engine oil, place some container underneath the engine and dispose it according to local regulations.
- Do not drain oil after running the engine. Allow engine to cool down sufficiently.

1. Change oil after the initial 50 hours of operation and every 200 hours thereafter.
2. Remove the drain plug at the bottom of the engine, and drain all the old oil. Drain oil will drain easier when the oil is warm.

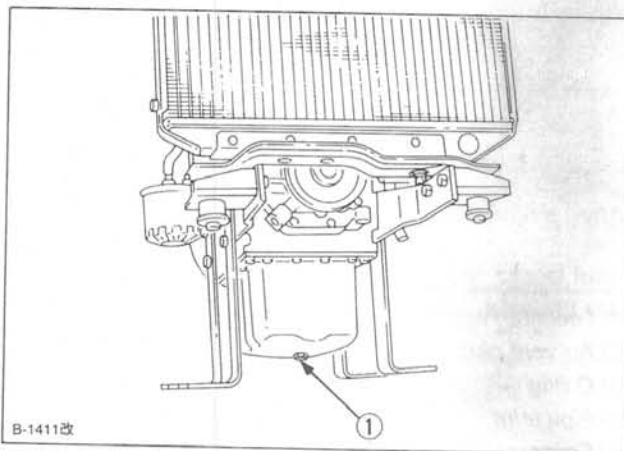

(1) Oil drain plug

3. Add new engine oil up to the upper limit of the oil level gauge.

■ Replacing the oil filter cartridge



CAUTION

To avoid personal injury:

- Be sure to stop the engine before changing the oil filter cartridge.
- Allow engine to cool down sufficiently, oil can be hot and cause burns.

1. Replace the oil filter cartridge after the initial 50 hours of operation and every 200 hours thereafter.
2. Remove the old oil filter cartridge with a filter wrench.
3. Apply a film of oil to the gasket for the new cartridge.
4. Screw in the cartridge by hand. When the gasket contacts the seal surface, tighten the cartridge enough by hand. Because, if you tighten the cartridge with a wrench, it will be tightened too much.

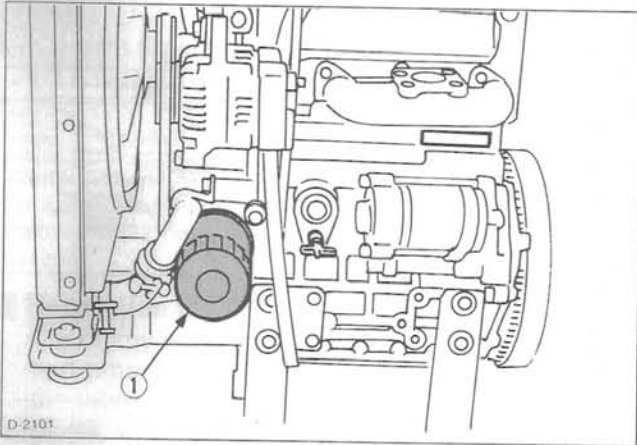

(1) Oil filter cartridge

Remove with a filter wrench

(Tighten with your hand)

5. After the new cartridge has been replaced, the engine oil level normally decreases a little. Thus, run the engine for a while and check for oil leaks through the seal before checking the engine oil level. Add oil if necessary.

NOTE:

- Wipe off any oil sticking to the machine completely.

RADIATOR

Coolant will last for one day's work if filled all the way up before operation. Make it a rule to check the coolant level before every operation.



WARNING

To avoid personal injury:

- Do not stop the engine suddenly, stop it after about 5 minutes of unloaded idling.
- Work only after letting the engine and radiator cool off completely (more than 30 minutes after it has been stopped).
- Do not remove the radiator cap while coolant is hot. When cool to the touch, rotate cap to the first stop to allow excess pressure to escape. Then remove cap completely. If overheats should occur, steam may gush out from the radiator or reserve tank; Severe burns could result.

■ Checking coolant level, adding coolant

1. Remove the radiator cap after the engine has completely cooled, and check to see that coolant reaches the supply port.

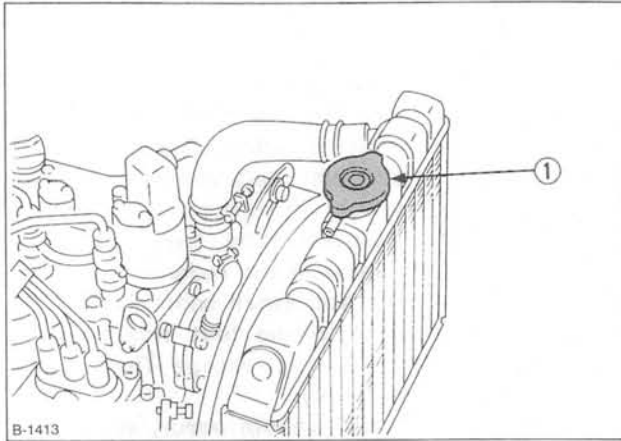

(1) Radiator pressure cap

2. If the radiator is provided with a reserve tank, check the coolant level of the reserve tank. When it is between the "FULL" and "LOW" marks, the coolant will last for one day's work.

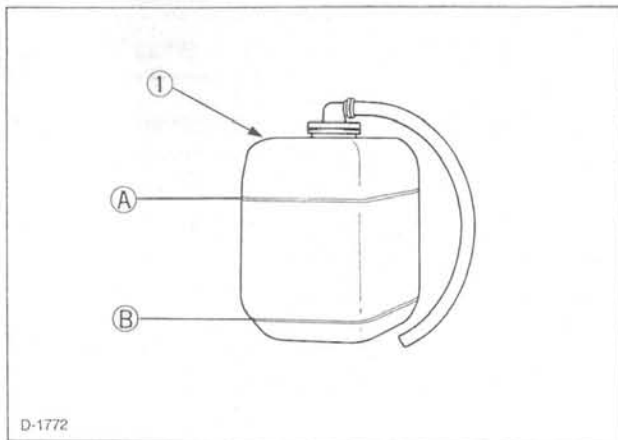

(1) Reserve tank

(A) "FULL"
(B) "LOW"

3. When the coolant level drops due to evaporation, add water only up to the full level.
4. Check to see that two drain cocks; one is at the crankcase side and the other is at the lower part of the radiator as figures below.

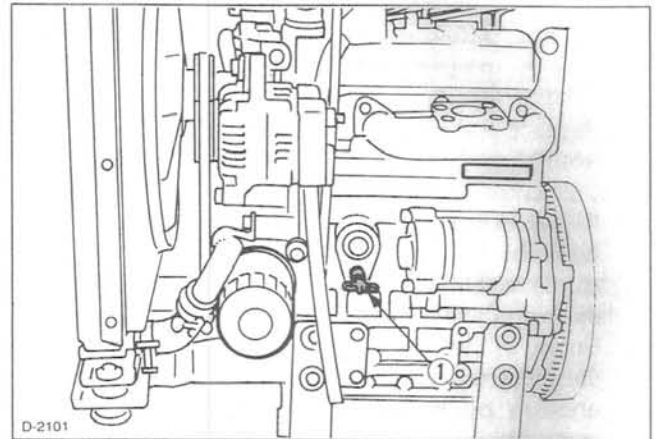

D-2101

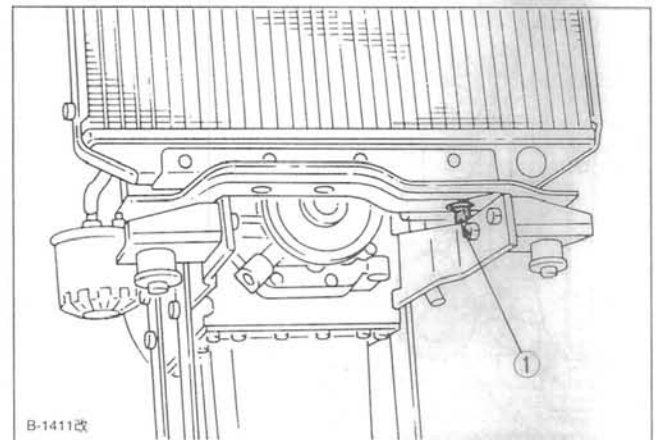

B-1411改

(1) Coolant drain cock

IMPORTANT:

- If the radiator cap has to be removed, follow the caution and securely retighten the cap.
- If coolant should be leak, consult your local KUBOTA dealer.
- Make sure that muddy or sea water does not enter the radiator.
- Use clean, fresh water and 50% anti-freeze to fill the recovery tank.
- Do not refill reserve tank with coolant over the "FULL" level mark.
- Be sure to close the radiator cap securely. If the cap is loose or improperly closed, coolant may leak out and decrease quickly.

■ Changing coolant

1. To drain coolant, always open both drain cocks and simultaneously open the radiator cap as well. With the radiator cap kept closed, a complete drain of water is impossible.
2. Remove the overflow pipe of the radiator pressure cap to drain the reserve tank.
3. Prescribed coolant volume (U.S.gallons)

Models	Quantity
D905-E, D1005-E, D1105-E, D1105-TE	3.1 L (0.82 U.S.gals.)
V1205-E, V1305-E, V1505-E	4.0 L (1.06 U.S.gals.)
V1205-TE, V1505-TE	5.0 L (1.32 U.S.gals.)

NOTE:

- Coolant quantities shown are for standard radiators.
4. An improperly tightened radiator cap or a gap between the cap and the seat quickens loss of coolant.
 5. Coolant (Radiator cleaner and anti-freeze)

Season	Coolant
Summer	Pure water and radiator cleaner
Winter (When temperature drops below 0°C (32°F)) or all season	Pure water and anti-freeze (See "Anti-freeze" in RADIATOR section)

■ Remedies for quick decrease of coolant

1. Check any dust and dirt between the radiator fins and tube. If any, remove them from the fins and the tube.
2. Check the tightness of the fan belt. If loose, tighten it securely.
3. Check the internal blockage in the radiator hose. If scale forms in the hose, clean with the scale inhibitor or its equivalent.

■ Checking radiator hoses and clamp



CAUTION

To avoid personal injury:

- Be sure to check radiator hoses and hose clamps periodically. If radiator hose is damaged or coolant leaks, overheats or severe burns could occur.

Check to see if radiator hoses are properly fixed every 200 hours of operation or 6 months, whichever comes first.

1. If hose clamps are loose or water leaks, tighten hose clamps securely.
2. Replace hoses and tighten hose clamps securely, if radiator hoses are swollen, hardened or cracked.

Replace hoses and hose clamps every 2 years, or earlier, if checked and found that hoses are swollen, hardened or cracked.

■ Precaution at overheating

Take the following actions in the event the coolant temperature is nearly or more than the boiling point, what is called "Overheating". Take these actions if the engine's alarm buzzer sounds or the alarm lamp lights up.

1. Stop the engine operation in a safe place and keep the engine unloaded idling.
2. Do not stop the engine suddenly. Stop it after about 5 minutes of unloaded idling.
3. If the engine stalls within about 5 minutes of running under no load, immediately leave and keep yourself away from the machine. Do not open the hood and any other part.
4. Keep yourself and others well away from the engine for further 10 minutes or while the steam blown out.
5. Checking that there gets no danger such as burn, get rid of the causes of overheating according to the manual, see "TROUBLESHOOTING" section. And then, start again the engine.

■ Cleaning radiator core (outside)

If dust is between the fin and tube, wash it away with running water.

IMPORTANT:

- Do not clean radiator with firm tools such as spatulas or screwdrivers. They may damage specified fin or tube. It can cause coolant leaks or decrease coolings performance.

■ Anti-freeze



CAUTION

To avoid personal injury:

- When using anti-freeze, put on some protection such as rubber gloves.
- If should drink anti-freeze, throw up at once and take medical attention.
- When anti-freeze comes in contact with the skin or clothing, wash it off immediately.
- Do not mix different types of anti-freeze.
- Keep fire and children away from anti-freeze.
- Be mindful of the environment and ecology. Before draining any fluids, find out the correct way of disposing by checking with local codes.
- Also, observe the relevant environmental protection regulations when disposing of oil, fuel, coolant, brake fluid, filters and batteries.

If it freezes, coolant can damage the cylinders and radiator. It is necessary, if the ambient temperature falls below 0°C (32°F), to remove coolant after operating or to add anti-freeze to it.

1. There are two types of anti-freeze available; use the permanent type (PT) for this engine.
2. Before adding anti-freeze for the first time, clean the radiator and engine interior by pouring fresh water, and draining it a few times.
3. The procedure for the mixing of water and anti-freeze differs according to the make of the anti-freeze and the ambient temperature. Refer to SAE J1034 standard, more specifically also to SAE J814c.
4. Mix the anti-freeze with water, and then fill into the radiator.

IMPORTANT:

- When the anti-freeze is mixed with water, the anti-freeze mixing ratio must be less than 50%.

Vol % Anti-freeze	Freezing Point		Boiling Point ※	
	°C	°F	°C	°F
40	-24	-12	106	222
50	-37	-34	108	226

※ At 1.013×10⁵Pa (760mmHg) pressure (atmospheric). A higher boiling point is obtained by using a radiator pressure cap which permits the development of pressure within the cooling system.

NOTE:

- The above data represents industry standards that necessitate a minimum glycol content in the concentrated anti-freeze.
- When the coolant level drops due to evaporation, add water only to keep the anti-freeze mixing ratio less than 50%. In case of leakage, add anti-freeze and water in the specified mixing ratio before filling into the radiator.
- Anti-freeze absorbs moisture. Keep unused anti-freeze in a tightly sealed container.
- Do not use radiator cleaning agents when anti-freeze has been added to the coolant. (Anti-freeze contains an anti-corrosive agent, which will react with the radiator cleaning agent forming sludge which will affect the engine parts.)

■ Radiator cement

As the radiator is solidly constructed, there is little possibility of water leakage. Should this happen, however, radiator cement can easily fix it. If leakage is serious, contact your local KUBOTA dealer.

AIR CLEANER

Since the air cleaner employed on this engine is a dry type, never apply oil to it.

1. Open the evacuator valve once a week under ordinary conditions — or daily when used in a dusty place. This will get rid of large particles of dust and dirt.
2. Wipe the inside air cleaner clean with cloth if it is dirty or wet.
3. Avoid touching the element except when cleaning.
4. When dry dust adheres to the element, blow compressed air from the inside turning the element. Pressure of compressed air must be under 205kPa (2.1kgf/cm², 30psi).
5. When carbon or oil adheres to the element, soak the element in detergent for 15 minutes, then wash it several times in water, rinse with clean water and dry it naturally.
6. After the element is fully dried, inspect the inside of the element with a light, and check if it is damaged or not. (referring to the instructions on the label attached to the element.)
7. Replace the element every year or every 6 cleanings.

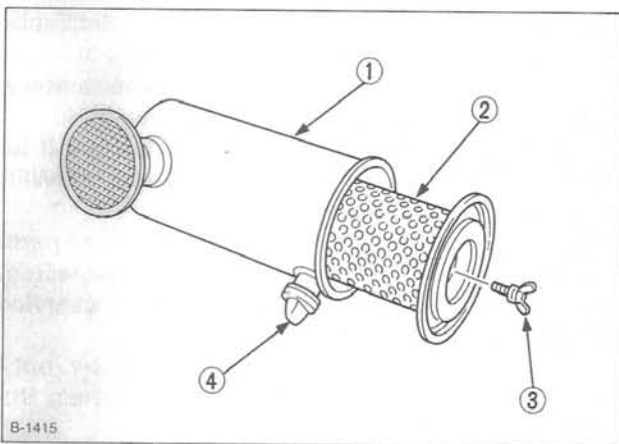

- B-1415
- (1) Air cleaner body
 - (2) Element
 - (3) Wing bolt
 - (4) Evacuator valve

IMPORTANT:

- Make sure the wing bolt for the element is tight enough. If it is loose, dust and dirt may be sucked in, wearing down the cylinder liner and piston ring earlier, and thereby resulting in poor power output.
- Do not overservice the air cleaner element. Overservicing may cause dirt to enter the engine causing premature wear. Use the dust indicator as a guide on when to service.

Evacuator valve

Open the evacuator valve once a week under ordinary conditions - or daily when used in a dusty place - to get rid of large particles of dust and dirt.

Dust indicator (optional)

If the red signal on the dust indicator attached to the air cleaner is visible, the air cleaner has reached the service level.

Clean the element immediately, and reset the signal with the "RESET" button.

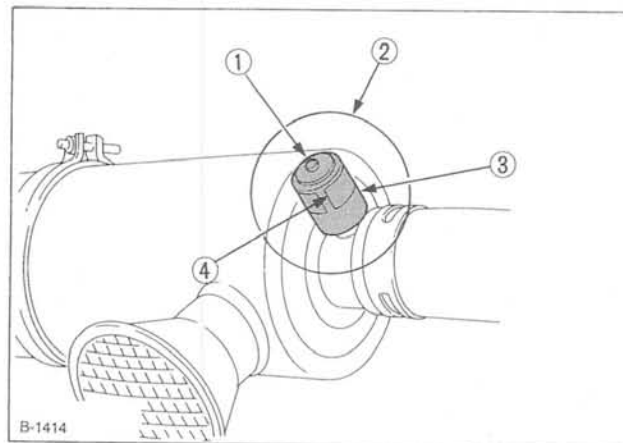

- B-1414
- (1) "RESET" button
 - (2) Dust indicator
 - (3) Service level
 - (4) Signal

■ For the air cleaner with a dust cup (optional)

Remove and clean out the dust cup before it becomes half full with dust; usually once a week, or even every day if the working surroundings are dusty.

Install the air cleaner dust cup with "TOP" indicated on the rear of the cup in the up position. (However, it may be installed in either direction when the cover is placed at the lower part.)

IMPORTANT:

- If the dust cup is mounted incorrectly, dust or dirt does not collect in the cup, and direct attachment of the dust to the element will cause its lifetime to shorten to a great extent.

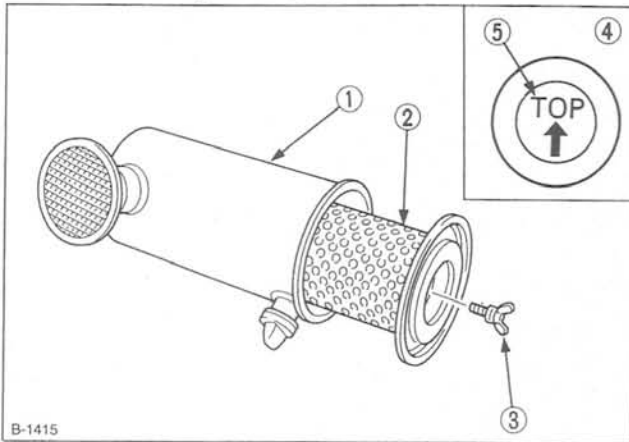

- B-1415
- (1) Air cleaner body
 - (2) Element
 - (3) Wing bolt
 - (4) Dust cup
 - (5) "TOP" mark

BATTERY



CAUTION

To avoid personal injury:

- Be careful not to let the battery electrolyte contact your body or clothing.
- Wear eye protection and rubber gloves, since the diluted sulfuric acid solution burns skin and eats holes in clothing. Should this occur, immediately wash it off with running water and get medical attention.

Mishandling of the battery shortens the service life and adds to maintenance costs. Obtain the maximum performance and the longest life of the battery by handling properly and with care.

Engine starting will be more difficult, if the battery charge is low. Be careful to recharge it at an early occasion before it is too late.

■ Battery charging



DANGER

The battery comes in two types: Refillable, Non-refillable.

- For using the refillable type battery, follow the instructions below.

Do not use or charge the battery if its fluid level stands below the LOWER (lower limit level) mark.

Otherwise, the battery component parts may deteriorate earlier than expected, which may shorten the battery's service life or cause an explosion.

Immediately, add distilled water until the battery's fluid level is between the UPPER and LOWER levels.



CAUTION

To avoid personal injury:

- When the battery is being activated, hydrogen and oxygen gases in the battery are extremely explosive. Keep open sparks and flames away from the battery at all times, especially when charging the battery.
- When charging the battery, remove the battery vent plugs.
- When disconnecting the cable from the battery, start with the negative terminal, and when connecting them, start with the positive terminal first.
- DO NOT check the battery charge by placing a metal object across the terminals. Use a voltmeter or hydrometer.

1. Make sure each electrolyte level is to the bottom of vent wells, if necessary, add only distilled water in a well-ventilated place.

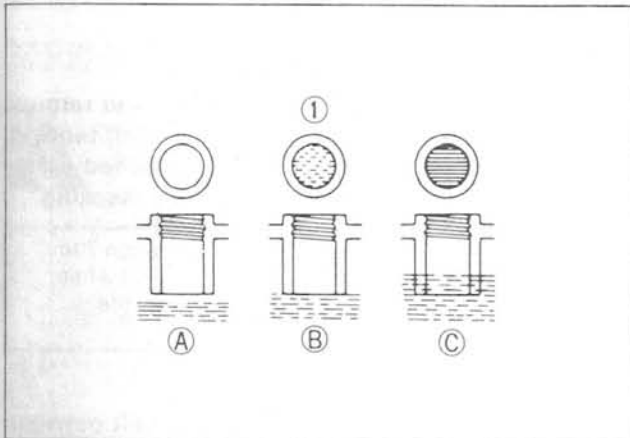

(1) Battery electrolyte level
 (A) "TOO LOW"
 (B) "PROPER"
 (C) "TOO HIGH"

2. To slow charge the battery, connect the charger positive terminal to the battery positive terminal, and the negative to the negative, then recharge in the standard fashion.
3. Quick recharging charges the battery at a high rate in a short time. This is only for emergencies.
4. Recharge the battery as early as possible, or battery life will be extremely shortened.
5. When exchanging an old battery for a new one, use a battery of equal specifications shown in page 26, 27.

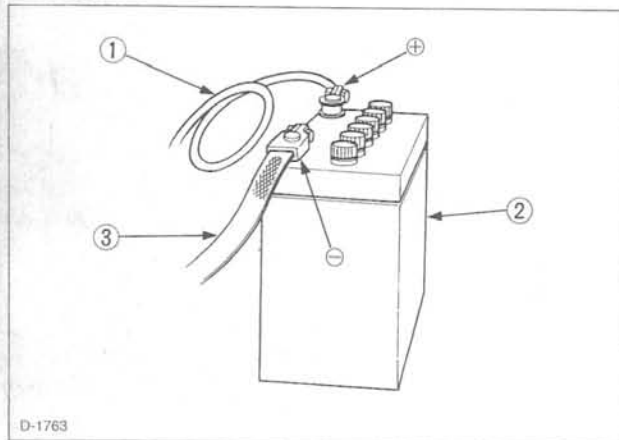

(1) Thick cable red (+)
 (2) Battery case
 (3) Earth cable black (-)

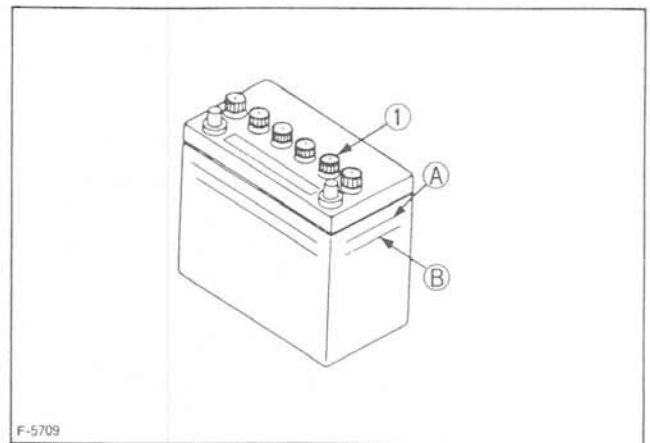

(1) Plug
 (A) "HIGHEST LEVEL"
 (B) "LOWEST LEVEL"

IMPORTANT:

- Connect the charger positive terminal to the battery positive terminal, and negative to the negative.
- When disconnecting the cable from the battery, start with the negative terminal first. When connecting the cable to the battery, start with the positive terminal first. If reversed, the contact of tools on the battery may cause a short.

Direction for long term storage

1. When storing the engine for long periods of time, remove the battery, adjust the electrolyte to the proper level, and store in a dry and dark place.
2. The battery naturally discharges while it is stored. Recharge it once a month in summer, and every 2 months in winter.

ELECTRIC WIRING



CAUTION

To avoid personal injury:

Shorting of electric cable or wiring may cause a fire.

- Check to see if electric cables and wiring are swollen, hardened or cracked.
 - Keep dust and water away from all power connections.
- Loose wiring terminal parts, make bad connections. Be sure to repair them before starting the engine.

Damaged wiring reduces the capacity of electrical parts. Change or repair damaged wiring immediately.

FAN BELT

■ Adjusting Fan Belt Tension



CAUTION

To avoid personal injury:

- Be sure to stop the engine and remove the key before checking the belt tension.
- Be sure to reinstall the detached safety shield after maintenance or checking.

Proper fan belt tension	A deflection of between 7 to 9 mm (0.28 to 0.35 in.) when the belt is pressed in the middle of the span.
-------------------------	--

1. Stop the engine and remove the key.
2. Apply moderate thumb pressure to belt between pulleys.
3. If tension is incorrect, loosen the alternator mounting bolts and, using a lever placed between the alternator and the engine block, pull the alternator out until the deflection of the belt falls within acceptable limits.
4. Replace fan belt if it is damaged.

IMPORTANT:

- If belt is loosen or damaged and the fan is damaged, it could result in overheats or insufficient charging. Correct or replace belt.

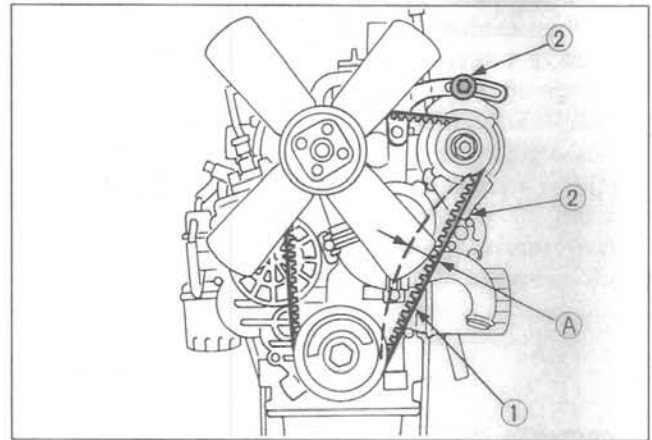

(1) Fan belt
(2) Bolt and nut

(A) 7 to 9 mm (0.28 to 0.35 in.)
(under load of 10 kgf (22.1 lbs))

CARRIAGE AND STORAGE

CARRIAGE



CAUTION

To avoid personal injury:

- Fix the engine securely not to fall during operation.
- Do not stand near or under the engine while carrying it.
- The engine is heavy. In handling it, be very alert not to get your hands and body caught in.

1. Use carrier such as crane when carrying the engine, or hurt your waist and yourself. Support the engine securely with rope not to fall while carrying it.
2. When lifting the engine, put the hook securely to metal fittings attached to the engine. Use strong hook and fittings enough to hang the engine.

STORAGE



CAUTION

To avoid personal injury:

- Do not clean the machine with engine running.
- To avoid the danger of exhaust fume poisoning, do not operate the engine in a closed building without proper ventilation.
- When storing the engine just after running, let the engine cool off.

Before storing the engine for more than a few months, remove any dirt on the machine, and:

1. Drain the coolant in the radiator. Open the cock at the bottom of the radiator, and remove the pressure cap to drain water completely. Leave the cock open. Hang a note written "No water" on the pressure cap. Since water may freeze when the temperature drops below 0°C (32°F), it is very important that no water is left in the machine.
2. Remove dirty engine oil, fill with new oil and run the engine for about 5 minutes to let the oil penetrate to all the parts.
3. Check all the bolts and nuts, and tighten if necessary.
4. Remove the battery from the engine, adjust the electrolyte level, and recharge it. Store the battery in a dry and dark place.
5. When the engine is not used for a long period of time, run it for about 5 minutes under no load every 2-3 months to keep it free from rust. If the engine is stored without any running, moisture in the air may condense into dew over the sliding parts of the engine, resulting in rust there.
6. If you forget to run the engine for longer than 5-6 months, apply enough engine oil to the valve guide and valve stem seal and make sure the valve works smoothly before starting the engine.
7. Store the engine in a flat place and remove the key from engine.
8. Do not store the engine in a place where has flammable materials such as dry grass or straw.
9. When covering the engine for storage, let engine and muffler cool off completely.
10. Operate the engine after checking and repairing damaged wirings or pipes, and clearing flammable materials carried by mouse.

TROUBLESHOOTING

If the engine does not function properly, use the following chart to identify and correct the cause.

■ When it is difficult to start the engine.

Cause	Countermeasures
Fuel is thick and doesn't flow.	<ul style="list-style-type: none"> * Check the fuel tank and fuel filter. Remove water, dirt and other impurities. * As all fuel will be filtered by the filter, if there should be water or other foreign matters on the filter, clean the filter with kerosene.
Air or water mixed in fuel system	<ul style="list-style-type: none"> * If air is in the fuel filter or injection lines, the fuel pump will not work properly. To attain proper fuel injection pressure, check carefully for loosened fuel line coupling, loose cap nut, etc. * Loosen joint bolt stop fuel filter and air vent screws of fuel injection pump to eliminate all the air in the fuel system.
Thick carbon deposits on orifice of injection nozzle.	<ul style="list-style-type: none"> * This is caused when water or dirt is mixed in the fuel. Clean the nozzle injection piece, being careful not to damage the orifice. * Check to see if nozzle is working properly or not. If not, install a new nozzle.
Valve clearance is wrong.	* Adjust valve clearance to 0.145 to 0.185 mm (0.0057 to 0.0072 in.) when the engine is cold.
Leaking valves	* Grind valves.
Fuel injection timing is wrong.	<ul style="list-style-type: none"> * Adjust injection timing * The injection timing 0.3 rad (18°) before top dead center.
Engine oil becomes thick in cold weather and engine cranks slow.	* Change grade of oil according to the weather (temperature.)
Low compression	* Bad valve or excessive wear of rings, pistons and liners cause insufficient compression. Replace with new parts.
Battery is discharged and the engine will not crank.	<ul style="list-style-type: none"> * Charge battery. * In winter, always remove battery from machine, charge fully and keep indoors. Install in machine at time of use.

■ When output is insufficient

Cause	Countermeasures
Carbon stuck around orifice of nozzle piece	<ul style="list-style-type: none"> * Clean orifice and needle valve, being very careful not to damage the nozzle orifice. * Check nozzle to see if good. If not, replace with new parts.
Compression is insufficient. Leaking valves	<ul style="list-style-type: none"> * Bad valve and excessive wear of rings, pistons and liners cause insufficient compression. Replace with new parts. * Grind valves.
Fuel is insufficient.	* Check fuel system.
Overheating of moving parts	<ul style="list-style-type: none"> * Check lubricating oil system. * Check to see if lubricating oil filter is working properly. * Filter element deposited with impurities would cause poor lubrication. Change element. * Check the clearance of bearing are within factory specs. * Check injection timing.
Valve clearance is wrong.	* Adjust to proper valve clearance of 0.145 to 0.185 mm (0.0057 to 0.0072 in.) with engine cold.
Air cleaner is dirty	* Clean the element every 100 hours of operation.
Fuel injection pressure is wrong.	* Adjust to proper pressure. 13.7 Mpa (140kgf/cm ² , 1991psi)
Injection pump wear	<ul style="list-style-type: none"> * Do not use poor quality fuel as it will cause wear of the pump. Only use No.2-D diesel fuel. * Check the fuel injection pump element and delivery valve assembly and replace as necessary.

NOTE:

- If the cause of trouble can not be found, contact your KUBOTA dealer.

■ When engine suddenly stops

Cause	Countermeasures
Lack of fuel	* Check the fuel tank and refill the fuel, if necessary. * Also check the fuel system for air or leaks.
Bad nozzle	* If necessary, replace with a new nozzle.
Moving parts are overheated due to shortage of lubrication oil or improper lubrication.	* Check amount of engine oil with oil level gauge. * Check lubricating oil system. * At every 2 times of oil change, oil filter cartridge should be replaced. * Check to see if the engine bearing clearances is within factory specs.

■ When color of exhaust is especially bad

Cause	Countermeasures
Fuel governing device bad	* Contact dealer for repairs.
Fuel is of extremely poor quality.	* Select good quality fuel Use No. 2-D diesel fuel only.
Nozzle is bad.	* If necessary, replace with new nozzle.
Combustion is incomplete.	* Cause is poor atomization, improper injection timing, etc. Because of trouble in injection system or in poor valve adjustment, or compression leakage, poor compression, etc. Check for the cause.

■ When engine must be stopped immediately

Cause	Countermeasures
Engine revolution suddenly decreases or increases.	* Check the adjustments, injection timing and the fuel system.
Unusual sound is heard suddenly.	* Check all moving parts carefully.
Color of exhaust suddenly turns dark.	* Check the fuel injection system, especially the fuel injection nozzle.
Bearing parts are overheated.	* Check the lubricating system.
Oil lamp lights up during operation.	* Check lubricating system. * Check, if the engine bearing clearances are within factory specs. * Check the function of the relieve valve in the lubricating system. * Check pressure switch. * Check filter base gasket.

■ When engine overheats

Cause	Countermeasures
Engine oil insufficient	* Check oil level. Replenish oil as required.
Fan belt broken or elongated	* Change belt or adjust belt tension.
Coolant insufficient	* Replenish coolant.
Excessive concentration of antifreeze	* Add water only or change to coolant with the specified mixing ratio.
Radiator net or radiator fin clogged with dust	* Clean net or fin carefully.
Inside of radiator or coolant flow route corroded	* Clean or replace radiator and parts.
Fan or radiator or radiator cap defective	* Replace defective part.
Thermostat defective	* Check thermostat and replace if necessary.
Temperature gauge or sensor defective	* Check temperature with thermometer and replace if necessary.
Overload running	* Reduce load.
Head gasket defective or water leakage	* Replace parts.
Incorrect injection timing	* Adjust to proper timing.
Unsuitable fuel used	* Use the specified fuel.

SPECIFICATIONS

Model		D905-E	D1005-E	D1105-E	D1105-TE			
Type		Vertical, water-cooled, 4-cycle diesel engine						
Number of cylinders		3						
Bore and stroke	mm (in.)	72×73.6 (2.83×2.90)	76×73.6 (2.99×2.90)	78×78.4 (3.07×3.09)				
Total displacement	cm ³ (cu. in)	898 (54.80)	1001 (61.08)	1123 (68.53)				
Combustion chamber		Spherical Type (E-TVCS)						
SAE NET Intermittent H.P. (SAEJ1349)	kW/min ⁻¹ (rpm) (HP/min ⁻¹ (rpm))	14.9/3000 (20.0/3000)	17.5/3600 (23.5/3600)	16.8/3000 (22.5/3000)	19.4/3600 (26.0/3600)	18.7/3000 (25.0/3000)	23.5/3000 (31.5/3000)	
SAE NET Continuous H.P. (SAEJ1349)	kW/min ⁻¹ (rpm) (HP/min ⁻¹ (rpm))	12.7/3000 (17.0/3000)	15.3/3600 (20.5/3600)	14.2/3000 (19.0/3000)	16.8/3600 (22.5/3600)	16.4/3000 (22.0/3000)	20.4/3000 (27.4/3000)	
Maximum bare speed	min ⁻¹ (rpm)	3200	3800	3200	3800	3200		
Minimum bare idling speed	min ⁻¹ (rpm)	850-950						
Order of firing		1-2-3						
Direction of rotation		Counter-clockwise (viewed from flywheel side)						
Injection pump		Bosch MD Type Mini Pump						
Injection pressure		13.73 MPa (140kgf/cm ² , 1991 psi)						
Injection timing (Before T.D.C.)		18°	21°	18°	21°	18°		
Compression ratio		23 : 1			24 : 1			
Fuel		Diesel Fuel No.2-D (ASTM D975)						
Lubricant (API classification)		above CD grade						
Dimensions (length×width×height)	mm (in.)	497.8×396×608.7 (19.60×15.59×23.96)					497.8×437.7×628.8 (19.60×17.23×24.76)	
Dry weight	kg (lbs.)	93 (205.0)					97 (213.8)	
Starting system		Cell starter (with glow plug)						
Starting motor		12 V, 1.0 kW						
Chargine generator		12V, 360 W						
Recommended battery capacity		12V, 65 AH, equivalent						

NOTE:

- Specifications are subject to change without notice.

V1205-E		V1205-TE		V1305-E		V1505-E		V1505-TE	
Vertical, water-cooled, 4-cycle diesel engine									
4									
72×73.6 (2.83×2.90)				76×73.6 (2.99×2.90)			78×78.4 (3.07×3.09)		
1198 (73.11)				1335 (81.47)			1498 (91.41)		
Spherical Type (E-TVCS)									
20.1/3000 (27.0/3000)	23.5/3600 (31.5/3600)	25.4/3000 (34.0/3000)	29.8/3600 (40.0/3600)	22.4/3000 (30.0/3000)	25.7/3600 (34.5/3600)	25.0/3000 (33.5/3000)		31.3/3000 (42.0/3000)	
17.2/3000 (23.0/3000)	20.1/3600 (27.0/3600)	21.6/3000 (29.0/3000)	25.7/3600 (34.5/3600)	19.0/3000 (25.5/3000)	22.4/3600 (30.0/3600)	21.6/3000 (29.0/3000)		27.2/3000 (36.5/3000)	
3200	3800	3200	3800	3200	3800	3200			
800~900									
1-3-4-2									
Counter-clockwise (viewed from flywheel side)									
Bosch MD Type Mini Pump									
13,73 MPa (140kgf/cm ² , 1991 psi)									
19°	22°	19°	22°	18°	21°	18°			
23 : 1		22.5 : 1		24 : 1			23.5 : 1		
Diesel Fuel No.2-D (ASTM D975)									
above CD grade									
583.8×396×613.7 (22.98×15.59×24.16)		591.3×439.2×613.7 (23.28×17.29×24.16)		583.8×396×613.7 (22.98×15.59×24.16)		591.3×396×613.7 (23.28×15.59×24.16)		591.3×439.2×613.7 (23.18×17.29×24.16)	
110 (242.5)		114 (251.3)		110 (242.5)			114 (251.3)		
Cell starter (with glow plug)									
12 V, 1.2 kW									
12V, 360 W									
12V, 70AH, equivalent									

WIRING DIAGRAMS

EC standard (Energize to run)

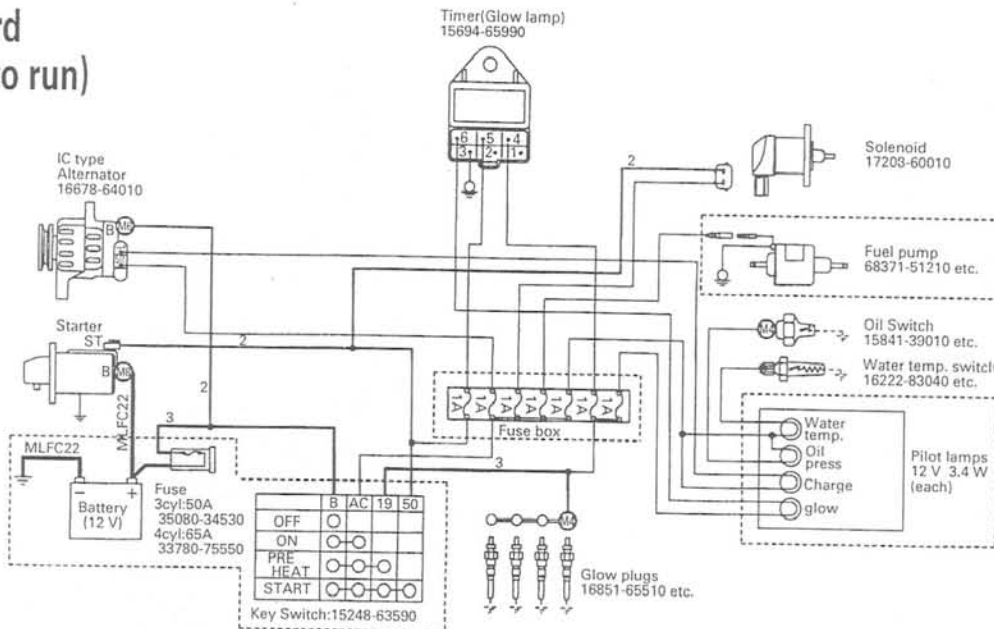

- ★ The parts boxed in [] are reference, NOT equipped for standard engine spec.
- ★ Non marked wire dia. is 0.8~1.25 mm².

KTC/SAE standard (Energize to run)

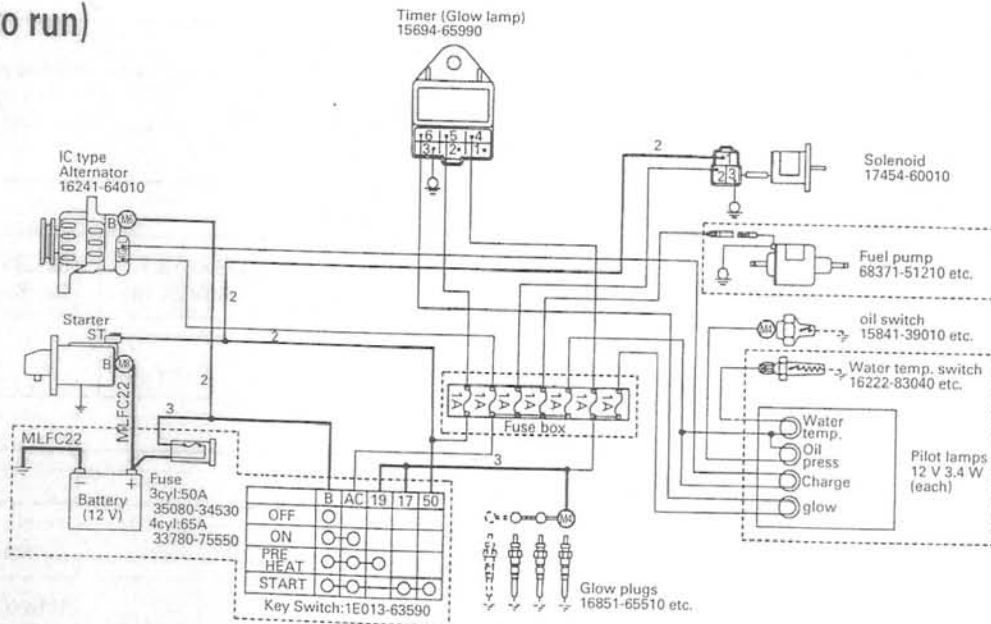

- ★ The parts boxed in [] are reference, NOT equipped for standard engine spec.
- ★ Non marked wire dia. is 0.8~1.25 mm².



MATERIAL SAFETY DATA SHEET

Section 1 - CHEMICAL PRODUCT AND COMPANY IDENTIFICATION

Marketed and Distributed by:

CHS Inc.
P.O. Box 64089
Mail station 525
St. Paul, MN 55164-0089

Transportation Emergency (CHEMTREC): 1-800-424-9300
Technical Information: 1-651-306-8443
MSDS Information: 1-651-306-8438

PRODUCT NAME ERC AW Hydraulic Oil, ISO (32, 46, 68, 100, 150)

MSDS: 0124-F1B0-1 - Rev.A (4.6.99)

COMMON NAME: Industrial hydraulic fluid
Approximate SAE grade 10W, 20, 30, 40

CHEMICAL FORMULA: Mixture

CHEMICAL NAME: Lubricating Oil

CHEMICAL FAMILY: Hydrocarbon

Section 2 - COMPOSITION AND INFORMATION ON INGREDIENTS

INGREDIENTS	PERCENTAGES (by weight)	PEL (OSHA)	TLV (ACGIH)	CAS #
Oil, Solvent Neutral	30-98%	N/A	5 mg/m ³ TWA (Oil Mist)	64742-65-0
Oil, Bright Stock	0-60%	N/A	5 mg/m ³ TWA (Oil Mist)	64721-1-4
Performance Additives	Proprietary	N/A	N/A	

(TWA) - Time Weighted Average is the employee's average airborne exposure in any 8-hour work shift of a 40-hour work week which shall not be exceeded.
(STEL) - Short Term Exposure Limit is the employee's 15-minute time weighted average exposure which shall not be exceeded at any time during a work day unless another time limit is specified.

Section 3 - HAZARDS IDENTIFICATION

EMERGENCY OVERVIEW

POTENTIAL HEALTH EFFECTS

ROUTES OF ENTRY: (Eye Contact, Dermal, Inhalation.)

ACUTE EFFECTS OF OVER EXPOSURE:

Eyes - Contact with eyes may cause irritation.

Skin - Contact with skin may cause irritation.

Inhalation - May cause irritation of the nose and throat.

Ingestion - May cause nausea and vomiting. Large quantities may effect the central nervous system.

CHRONIC EFFECTS OF OVER EXPOSURE: No adverse effects anticipated.

MEDICAL CONDITIONS AGGRAVATED BY EXPOSURE: Existing dermatitis and respiratory conditions.

CARCINOGENICITY: NTP: No

IARC: No

OSHA: No

Section 4 - FIRST AID MEASURES

EMERGENCY AND FIRST AID PROCEDURES:

Eye Contact - If material comes in contact with the eyes, immediately wash the eyes with large amounts of water for fifteen minutes, occasionally lifting the lower and upper lids. Get medical attention.

Skin Contact - If the material comes in contact with the skin, wash the contaminated skin with soap and water promptly. If the material penetrates through clothing, remove the clothing and wash the skin with soap and water promptly. If irritation persists after washing, get medical attention immediately.

Inhalation - If person breathes in large amounts of material, move the exposed person to fresh air at once. If breathing has stopped, perform artificial respiration. Keep the person warm and at rest. Get medical attention as soon as possible.

Ingestion - If material has been swallowed, do not induce vomiting. Get medical attention immediately.

Section 5 - FIRE - FIGHTING MEASURES

FLASH POINT: >390°F (>200°C)

AUTO IGNITION TEMP: >400°F

FLAMMABLE LIMITS IN AIR
% BY VOLUME

LOWER
N/A

UPPER
N/A

EXTINGUISHING MEDIA: Use water spray to cool fire exposed surfaces and to protect personnel. Use foam, dry chemical or water spray (fog) to extinguish fire.

SPECIAL FIRE FIGHTING PROCEDURES: When fighting fires wear full turnout gear and self contained breathing apparatus. Water may cause splattering. Material floats on water.

UNUSUAL FIRE AND EXPLOSION HAZARDS: Toxic fumes gases or vapors may evolve on burning.

HAZARD RATINGS:	NFPA 704:	Health- <u>1</u>	Fire- <u>1</u>	Reactivity- <u>0</u>
	HMIS:	Health- <u> </u>	Fire- <u> </u>	Reactivity- <u> </u>

Section 6 - ACCIDENTAL RELEASE MEASURES

STEPS TO TAKE IF MATERIAL IS RELEASED OR SPILLED: Personal protective equipment should be worn. Ventilate area if confined or poorly ventilated. Contain with dikes or absorbent to prevent migration to sewers/streams. Take up small spill with dry chemical absorbent; large spills may require pump or vacuum prior to absorbent. May require excavation of severely contaminated soil. Avoid contact with skin and eyes.

Section 7 - HANDLING AND STORAGE

HANDLING AND STORING: Store in closed container away from all ignition sources. Handling temperatures should not exceed 175°F (80°C). Wash thoroughly after handling. Do not store at temperatures exceeding 113°F (45 C). Odorous and toxic fumes may form from the decomposition of this product if stored at excessive temperatures for extended periods of time. Open containers carefully and only in well ventilated areas or use appropriate respiratory protection. Store in well ventilated area.

Section 8 - EXPOSURE CONTROL - PERSONAL PROTECTION

ENGINEERING CONTROLS: Ventilate to control mists and vapors below exposure limits.

RESPIRATORY EQUIPMENT: Normally not required, if exposure limits are exceeded use a Niosh approved organic vapor respirator. Self contained breathing apparatus is recommended for entry into confined spaces or other poorly ventilated areas and for large spill clean-up sites.

EYE PROTECTION: Chemical goggles or faceshield recommended to minimize eye contact.

PROTECTIVE CLOTHING: Impervious (nitrile) gloves recommended when handling material to minimize exposure. Long sleeve shirts, chemically protective aprons and chemically protective boots are recommended for contact exposure or spill clean-up. Do not wear watches, rings or similar apparel that could entrap the material next to the skin.

OTHER (SAFETY SHOWERS, EYE WASH STATIONS, ETC.): Water should be available for flushing and washing when exposure exists. Launder soiled clothes. Discard shoes or other leather articles saturated with the material.

Section 9 - PHYSICAL AND CHEMICAL PROPERTIES

APPEARANCE: Amber liquid

ODOR: Mild odor

BOILING POINT: N/D

SPECIFIC GRAVITY (water=1): 0.8400 - 0.8800

VAPOR PRESSURE: <1 mm Hg 68° F

VAPOR DENSITY (air=1): N/D

SOLUBLE IN WATER: Insoluble

EVAPORATION RATE (ether=1): <1

pH: N/D

Section 10 - STABILITY AND REACTIVITY

STABILITY:

STABLE (At room temperature and pressure. See handling and storage section)

UNSTABLE

INCOMPATIBILITY -

CONDITIONS TO AVOID: See handling and storage section.

MATERIALS TO AVOID: Acids, oxidizing agents.

HAZARDOUS DECOMPOSITION PRODUCTS: Smoke, carbon monoxide, aldehydes, hydrogen sulfide and alkyl mercaptans may be released. Under combustion conditions, oxides of the following elements will be formed: Magnesium, calcium, nitrogen, sulfur, carbon.

HAZARDOUS POLYMERIZATION: Will not occur.

Section 11 - TOXICOLOGY INFORMATION

Note: CHS Inc. has not conducted specific toxicity tests on this product.

Section 12 - ECOLOGICAL INFORMATION

Note: CHS Inc. has not conducted specific ecological tests on this product.

Section 13 - DISPOSAL CONSIDERATION

WASTE DISPOSAL PROCEDURES: Place contaminated materials in a disposable container and dispose of in accordance with Local, State and Federal environmental regulations.

Section 14 - TRANSPORTATION

DOT PROPER SHIPPING NAME: N/A

DOT HAZARD CLASS: N/A

DOT IDENTIFICATION NUMBER: N/A

DOT EMER. RESPONSE GUIDE NO.: N/A

Section 15 - REGULATORY INFORMATION

This product does contain toxic chemicals subject to the reporting requirements of SARA Section 313 of the Emergency Planning and Community Right-To-Know Act of 1986 and of 40 CFR 372.

CAS Number
N982

Chemical Name
Zinc compounds

Percent by Weight
0.45% (0.03% as Zn)
Below *de minimus* level

SARA SECTION 311-312 HAZARD CATEGORIES (40 CFR 370.2):

FIRE: NoSUDDEN RELEASE OF PRESSURE: NoREACTIVE: NoACUTE: No CHRONIC: No

Section 16 - OTHER INFORMATION

Prepared By: Hue LamDATE: April 14, 1999Approved By: Marc SiebertSupersedes: N/ATitle: Manager, Quality SystemReason for Issue: CHS Inc. Marketer

THE INFORMATION CONTAINED IN THIS MSDS RELATES ONLY TO THE SPECIFIC MATERIAL IDENTIFIED. IT DOES NOT COVER USE OF THAT MATERIAL IN COMBINATION WITH ANY OTHER MATERIAL OR IN ANY PARTICULAR PROCESS. IN COMPLIANCE WITH 29 C.F.R. 1910.1200(g), CHS INC. HAS PREPARED THIS MSDS IN SEGMENTS, WITH THE INTENT THAT THOSE SEGMENTS BE READ TOGETHER AS A WHOLE WITHOUT TEXTUAL OMISSIONS OR ALTERATIONS. CHS INC. BELIEVES THE INFORMATION CONTAINED HEREIN TO BE ACCURATE, BUT MAKES NO REPRESENTATION, GUARANTEE, OR WARRANTY, EXPRESS OR IMPLIED, ABOUT THE ACCURACY, RELIABILITY, OR COMPLETENESS OF THE INFORMATION OR ABOUT THE FITNESS OF CONTENTS HEREIN FOR EITHER GENERAL OR PARTICULAR PURPOSES. PERSONS REVIEWING THIS MSDS SHOULD MAKE THEIR OWN DETERMINATION AS TO THE MATERIAL'S SUITABILITY AND COMPLETENESS FOR USE IN THEIR PARTICULAR APPLICATIONS.