

SP 300 DUAL SPRAY/SQUEEGEE MACHINE

Operating Instructions & Parts Manual



SealMaster[®]

Pavement Products & Equipment

PO Box 2277 • Sandusky, Ohio 44870 • 419-626-4375

SealMaster[®]

ThorWorks Industries, Inc.

Purchased by _____ Model NO. _____
Company Name _____ Serial NO. _____
Address _____ Acceptance Date _____
City _____ State _____ Zip _____

CORRESPONDENCE

All Correspondance regarding this equipment, as well as general correspondence should be addressed to:

ThorWorks Industries, Inc.
PO Box 2277
Sandusky, OH 44870

In referring to the equipment, kindly state the Model Number, Serial Number and any part number involved



CALIFORNIA

Proposition 65 Warning

Diesel engine exhaust and some of its constituents are known to the State of California to cause cancer, birth defects, and other reproductive harm.

SP300 Dual

PURCHASED BY: _____

MODEL NO. _____

COMPANY NAME: _____

SERIAL NO. _____

ADDRESS: _____

ACCEPTANCE DATE: _____

CITY: _____ STATE: _____ ZIP: _____

CORRESPONDENCE:

All correspondence regarding this equipment, as well as general correspondence should be addressed to:

SealMaster
P.O. Box 2277
Sandusky, Ohio 44870

In referring to the equipment, kindly state the Model Number, Serial Number, and part number involved.

SealMaster Limited Warranty

SealMaster warrants that its products are of quality material and workmanship. SealMaster agrees to replace, within a period of one (1) year from date of delivery, or at its option, repair, without charge, any part of their manufacture which proved defective. The repair or replacement will be free of charge F.O.B Sandusky, Ohio, proving the damaged part or parts are returned, freight prepaid, to SealMaster and investigation show such repair or replacement is made necessary by inherent defect of material or workmanship.

It is hereby understood that engines, motors, pumps, or other components purchased by SealMaster for use on its equipment are not warranted by SealMaster and are sold only with the standard warranty of the manufacturer of that component.

SealMaster will make no allowances for repairs or alterations completed by outside sources unless authorization is in writing and approved by an authorized SealMaster representative.

Any claims for defective material or workmanship must be made prior to the expiration of thirty (30) days from the date failure occurs, and in all cases prior to the expiration of the warranty period of one (1) year. It is the intent of this paragraph to limit SealMaster's liability solely to the cost of replacement parts, F.O.B. factory, or at the option of SealMaster to repair of the defective part or parts. No allowances for damages, lost time, or any other claim will be recognized.

This warranty is null and void if other than genuine SealMaster parts are used.

SealMaster is constantly striving to improve their products. Changes in design and improvement will be made whenever the manufacturer believes the efficiency of the product will be improved, without incurring any obligation to incorporate such improvements in any machines which have been shipped or are in service.

In an effort to continue to improve product quality, SealMaster reserves the right to change specifications without notice.

Any modification or alteration of this machine without prior approval of the manufacturer may void this warranty.

TANK CHART FOR SP300

(DIMENSIONS ARE 42" DIAMETER X 53" LONG)

TOTAL CAPACITY 318 GALLONS

Material Depth (inches)	Gallons	Material Depth (inches)	Gallons	Material Depth (inches)	Gallons
42	318	28	225	14	93
41	316	27	217	13	84
40	312	26	207	12	75
39	308	25	196	11	66
38	303	24	187	10	59
37	296	23	179	9	50
36	290	22	169	8	42
35	284	21	159	7	34
34	276	20	149	6	28
33	268	19	139	5	22
32	259	18	131	4	15
31	252	17	122	3	10
30	243	16	111	2	6
29	234	15	101	1	2

IMPORTANT:

Before operating your new SealMaster machine:

1. Read the operating instructions and all component manuals.
2. Check all nuts, bolts, and set screws for tightness. The nuts, bolts, and set screws are machine tightened before leaving the factory, however, some loosening may occur during shipment.
3. Read maintenance instructions.

MAINTENANCE:

A. ENGINE OIL:

1. Change engine oil frequently. Follow the instructions in the engine manual for type and changing schedule.

B. HYDRAULIC OIL:

1. Check the hydraulic oil level before each day of operation. The proper level is 6 inches below the top of the tank.
2. Hydraulic oil should be changed at least once each year. Use grade 68, ASTM Grade 315, viscosity 330 SUS 100° F Hydraulic oil.

C. Read the following operating procedures and maintenance schedule as listed in the respective manuals provided for the engine, motors, pumps, and valves.

D. BEARINGS:

1. All bearings should be greased once every month.
2. Check the tightness of all set screws.

E. MATERIAL PUMP:

1. Change diaphragms yearly.
2. Inspect checkballs and seats every two years. Change as necessary.
3. Check electrical connections for corrosion and tightness.
4. Clean inside of surge tank yearly.

F. FRONT STEERING SHAFT:

1. Grease the steering shaft weekly. Inspect the bearings yearly.

G. TIRES:

1. Always check air pressure.
2. Check tightness of lug nuts. Torque to 90 lbs. ft.

H. AFTER WORK MAINTENANCE:

1. Refer to water flush instructions discussed later in this manual.
2. Do not let material set in material tank for more than two days without removing or agitating.

BEFORE STARTING ENGINE:

1. Follow the maintenance procedures listed in the engine manual.
2. Check the gas supply.
3. Make sure the forward/reverse lever, located at the left of the steering wheel, is in the neutral position.
4. Make sure all valves are closed and the toggle switches are to the off position.

CAUTION

Do not operate the engine with the shrouds removed.

Do not place hands or solid objects into material hopper with the engine running.

TO START ENGINE:

1. Position yourself in the operator's seat.
2. Pull the throttle handle, located to the right of the steering wheel, 1/3 of the way up.
3. COLD ENGINE — Pull choke knob, located on the control panel, in front of the steering wheel, all of the way out and turn the key switch, if the engine does not start, repeat this procedure. Use the choke moderately. Allow the engine to warm up before operating.
4. WARM ENGINE — It should not be necessary to use the choke when the engine is warm. However, this may vary with each engine. This will require the operator to become familiar with the unit.

TO OPERATE MACHINE:

1. To move the machine forward, push forward/reverse control lever 64 forward SLOWLY, until your desired speed is reached. To move the machine in reverse, pull the lever to neutral, then to the reverse position.

**NEVER OPERATE MACHINE IN REVERSE WITH
REAR ASSEMBLY IN THE DOWN POSITION!!!**

FILLING MATERIAL TANK:

1. When cutting material in the machine, always place sealer in the tank before adding water.
2. Start the agitator by moving valve lever H-13 to the forward position. The farther you move the lever the faster the agitator will rotate. After mixing, bring the lever back towards neutral so that the agitator is rotating slowly.
3. To avoid build up of sand on the sides of the machine, always pour sand into the center of the tank. The usual amount of sand used to provide an anti-skid surface or to fill porous pavement is three (3) pounds per gallon of sealer. This will vary according to the porosity of the surface you are sealing.

FILLING THE TANK FROM DRUMS:

1. Make sure all valves are closed.
2. Connect a suction hose to ball valve 8-B, located on the right side of the basket strainer. Put the other end into the drum.
3. Open ball valve 8-B and ball valve 7-C, located on the recirculation line leading back into the material tank on top.
4. Engage toggle switch 19-M labeled material pump, to the UP position.
5. Turn pump speed control H-10, located on your right, counter clockwise until the desired volume is obtained.
6. After the drum is emptied, close the pump speed control FIRST, and then turn off the pump toggle switch 19-M.

OPERATING WATER FOG BAR:

CAUTION: NEVER RUN WATER

PUMP WITH WATER TANK EMPTY!!!

1. During very hot weather a better adhesion of sealer to blacktop can be obtained by use of the water fog bar. Water spray will cool down the asphalt and help mix any dust missed during the cleaning operation. The water tank fill is located under the left side step. Always use clean water to avoid plugging water lines.
2. Engage water toggle switch 19-W, labeled water pump, to the UP position.
3. Hold in on the button above the water toggle switch 19-W until the water starts to spray out. This activates the pump pressure safety switch which will stop when the water tank runs dry.

SEALER APPLICATION – SPRAY BAR:

1. Make sure all valves and toggle switches are OFF. Check basket filter and clean if necessary.
2. Add Sealer and water to desired consistency.
3. Engage agitator valve lever H-13 to the forward position.
4. Slowly add the desired amount of sand.
5. The agitator should remain on until the tank has been emptied, rotating slowly.
6. Open the main supply ball valve 8-G, located on the side of the basket strainer.
7. Open the recirculation ball valve 7-C, located just to the right of the control panel.
8. Engage toggle switch 19-M "LABELED MATERIAL PUMP" to the UP position.
9. Turn pump speed control H-10, "LABELED PUMP SPEED CONTROL", counterclockwise. The sand pump will now start to stroke slowly back and forth. Turning valve H-10, more counterclockwise will increase speed of the pump. This will in turn increase output volume.
10. Let the pump recirculate the material for a few minutes, then close recirculation ball valve 7-C.
11. Let the pump stroke and build up pressure until the pressure gauge H-17, located under the pump speed control, shows 800 psi. NOTE: For thick mixes you may have to increase the pump pressure.
12. Pump pressure control H-6, located to your right regulates pump output pressure. Turning it in, or clockwise, will increase pressure.
13. Open ball valve 8-K, located right before the suction hose leading to the spray bar.
14. Engage forward-reverse lever located on the left side of the steering wheel.
15. Twist spray bar ball valve handle 8-L. This opens the spray valves on the spray bar. To start your spraying application, adjust the pump speed control H-10, and pump pressure control H-6, to obtain the desired intensity of spray. Look at the pressure gauge and obtain the pressure reading. In the future, you can set the pressure to this reading to achieve the same results.
16. When you reach the end of the lot and wish to turn off the spray. Twist spray bar ball valve handle 8-L, the opposite way. This closes the spray valves instantly, eliminating any dripping. The sand pump will go to neutral and stop stroking until you reopen the spray bar. Leaving the pump in the neutral mode for extended periods of time will not harm the pump. The hydraulic system is pressure and flow compensated, which is designed just for this purpose.

SPRAY WAND:

FOLLOW STEPS 1 TO 12 REFERRED TO IN THE SPRAY BAR INSTRUCTIONS

13. Open ball valve 9-N located at the beginning of the spray wand hose, coming off the material pump.
14. Open ball valve 12-O located on the wand.
15. Increase or decrease the pressure by using the pump pressure control H-6.

SQUEEGEE APPLICATION OF SEALER:

FOLLOW STEPS 1 TO 3 REFERRED TO IN FILLING MATERIAL TANK INSTRUCTIONS.

13. Lower the rear end assembly by moving the valve lever H-14, labeled rear assembly UP-DOWN, to down position.
14. Place your feet on the peddles and press down with the heel part of your foot to open valves. Press with your toe to close the valves. Keep sealer in a roll of 1 to 3 inches for a full 90 inch application. If you are sealing on a hill going horizontal, use only the flow control valve toward the top of the hill. This will prevent material from running out of the forward squeegee box.
15. The rear squeegee can be angled left or right by squeezing the lever to the left of the seat, and pushing forward or pulling back. Angling the squeegee allows the operator to leave a "wet" edge on extremely long pulls.

WATER FLUSH:

1. Make sure all valves are closed.
2. Open small ball valve 32, located on the basket strainer.
3. Engage material pump toggle switch 19-M, to the UP position.
4. Turn pump speed control H-10, counterclockwise.
5. To flush water out through the spray bar:
 - A. Open ball valve 8-K located at the beginning of the suction hose leading to the spray bar.
 - B. Twist spray bar lever 8-L, to open the spray bar valves.
6. To flush water out through the spray wand:
 - A. Open small ball valve 9-N, located at the beginning of the spray wand hose, coming off the material pump.
 - B. Open ball valve 12-O, located on the wand.
7. CLOSE the water flush ball valve when done.

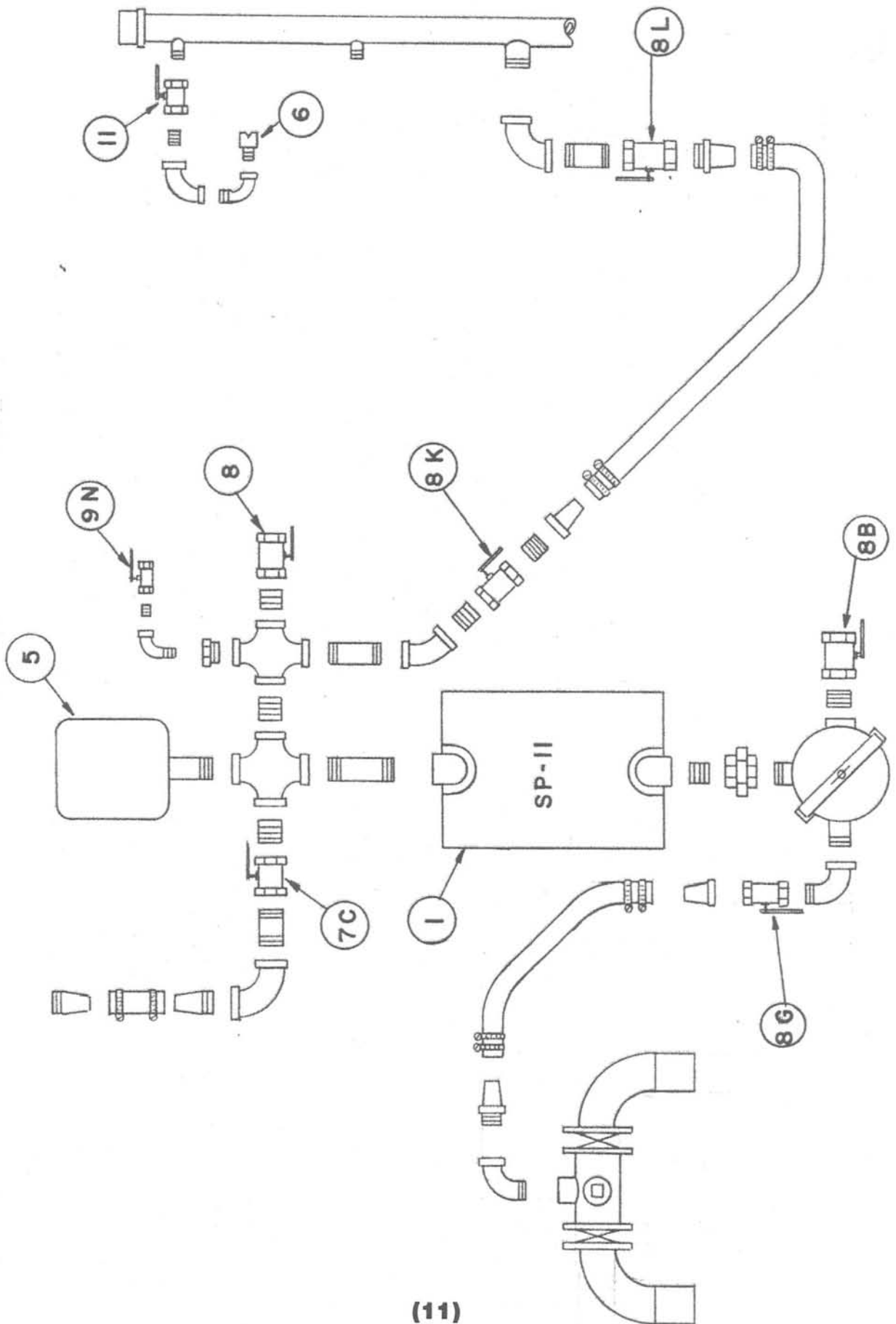

(11)

MATERIAL SCHEMATICS:

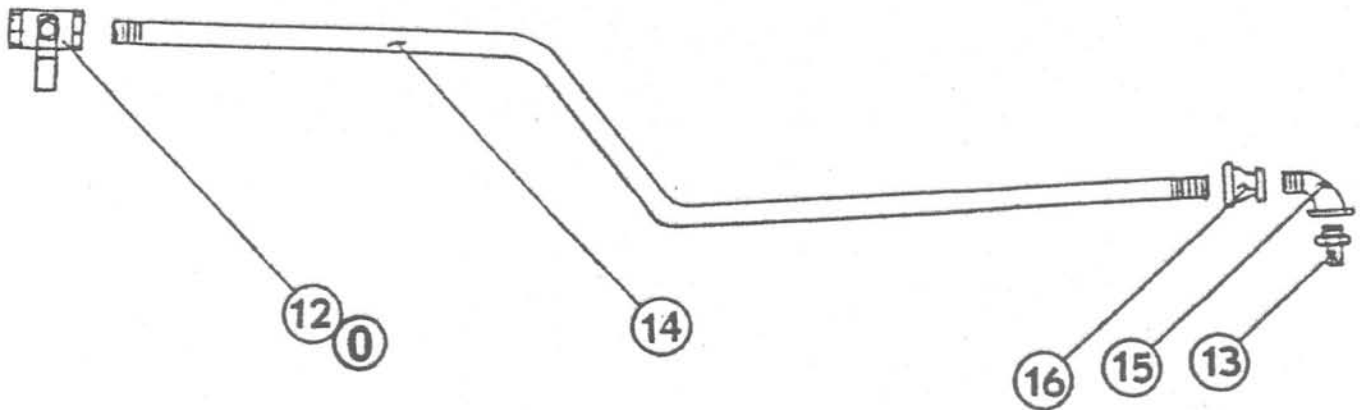

- | | | | |
|-----|------------|---|----------------------------------|
| 1. | P640A024 | — | SandPumper II Material Pump |
| 2. | P50147B002 | — | Basket Strainer complete |
| 3. | P50313A | — | Filter Basket only |
| 4. | P50319A | — | Seal-Basket Strainer |
| 5. | P30003C | — | Surge Tank |
| 6. | P449A008 | — | Spray Nozzle 80-50 |
| 7. | P397A002 | — | 2 inch Brass Ball Valve |
| 8. | P397A002 | — | 2 inch Brass Ball Valve |
| 9. | P397A001 | — | 3/4 inch Brass Ball Valve |
| 10. | P398A009 | — | 3 inch Butterfly Valve |
| 11. | P397A010 | — | 1/2 inch Brass Ball Valve |
| 12. | P397A010 | — | 3/4 inch Carbon Steel Ball Valve |
| 13. | P449A008 | — | Spray Nozzle 80/50 |
| 14. | P50274A | — | Conduit - Wand |
| 15. | P1007A001 | — | Street Elbow 90 Degree |
| 16. | P1001A006 | — | Reducing Coupling |
| 17. | P754B025 | — | 50 Ft. Spray Wand Hose |
| 18. | P754B027 | — | 100 Ft. Spray Wand Hose |

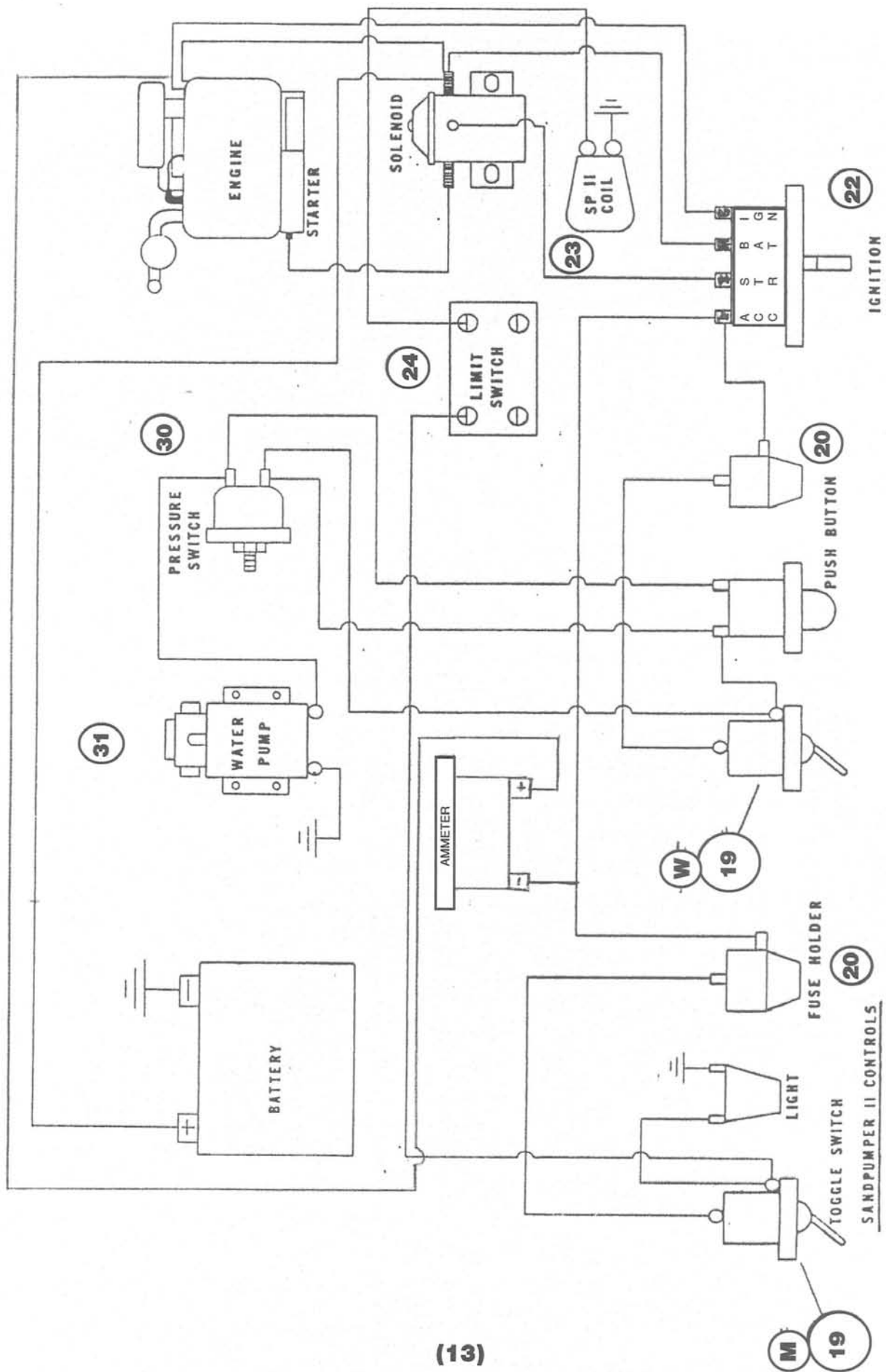

ELECTRICAL SCHEMATICS:

19.	P443A001	—	Toggle Switch
20.	P461A001	—	Fuse Holder
21.	P466A001	—	Battery
22.	P442A001	—	Ignition Switch
23.	P694A001	—	Coil
24.	P442A003	—	Limit - Snap Switch
25.	P436A001	—	Starter Solenoid
26.	P475B003	—	Battery Cable 24" - Negative
27.	P475B002	—	Battery Cable 17" - Positive
28.	P595A001	—	Fuse - ABC - 10 (Located in Water Fuse Holder)
29.	P595A002	—	Fuse - ABC - 5 (Located in SPII Fuse Holder)
30.	P914A001	—	Pressure Switch

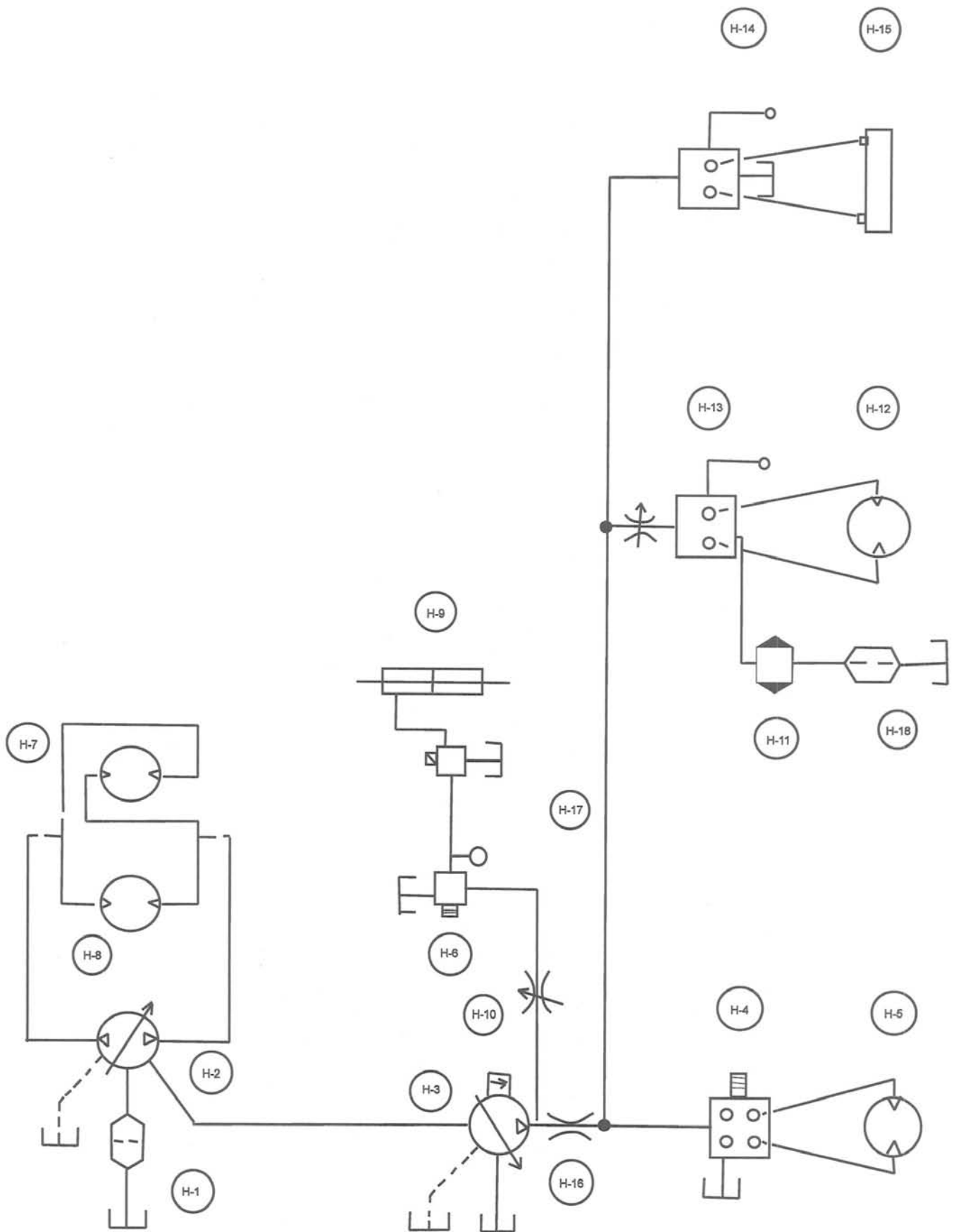

HYDRAULICS SCHEMATICS:

H-1	P908A005	—	Suction Line Filter
H-2	P707A002	—	Transmission
H-3	P601A009	—	Pressure Compensated Pump
H-4	P936A002	—	Steering Control
H-5	P474A004	—	Steering Motor
H-6	P693A008	—	Pump Pressure Control
H-7	P474A022	—	Left Rear Drive Motor
H-8	P474A023	—	Right Rear Drive Motor
H-9	P600A007	—	SandPumper II Pump Cylinder
H-10	P666A004	—	Pump Speed Control
H-11	P716A001	—	Oil Cooler
H-12	P474A002	—	Agitator Motor
H-13	P472A011	—	Agitator Control Valve
H-14	P472A012	—	Squeegee Assembly Up-Down Valve
H-15	P600A005	—	Cylinder
H-16	P472A013	—	3 GPM Orifice
H-17	P711A003	—	2000 psi Gauge
H-18	P908A003	—	Return Line Filter

WATER SCHEMATICS:

- 31. P593A001 — Electric Water Pump
- 32. P397A001 — 3/4" Ball Valve
- 33. P449A001 — 6503 Spray Tip
- 34. P596A001 — Water Tanks

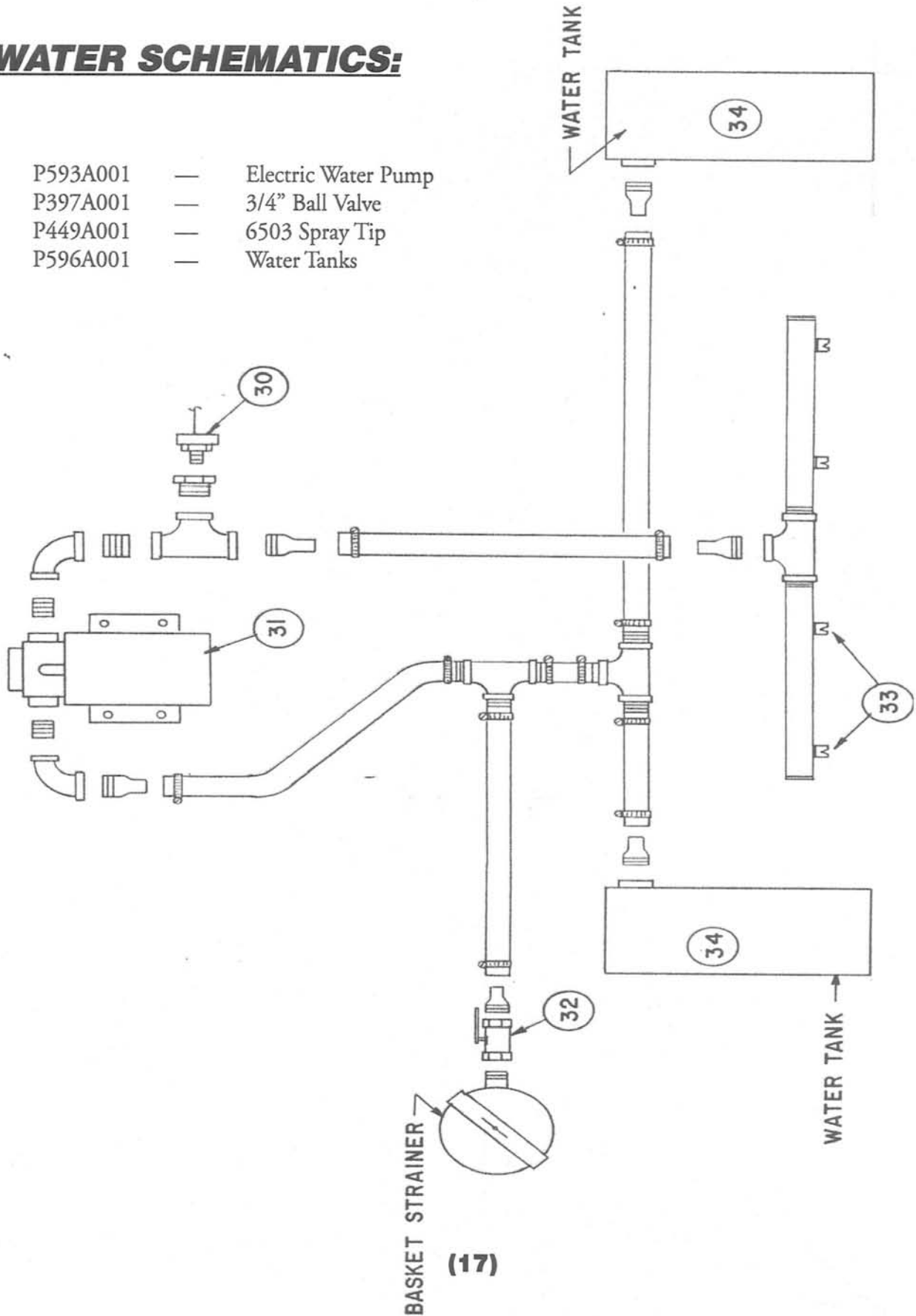

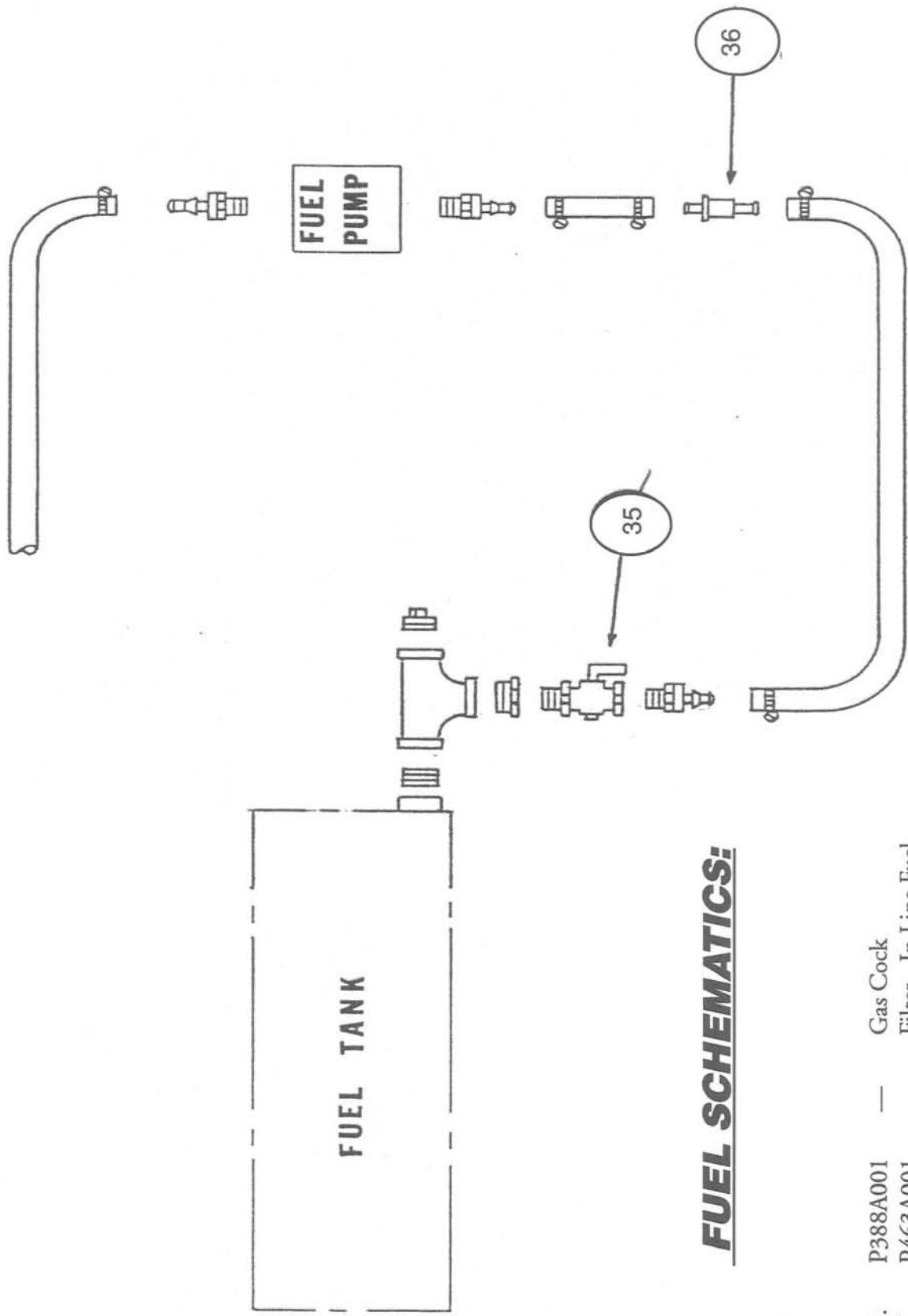

FUEL SCHEMATICS:

- 35. P388A001 — Gas Cock
- 36. P463A001 — Filter - In Line Fuel

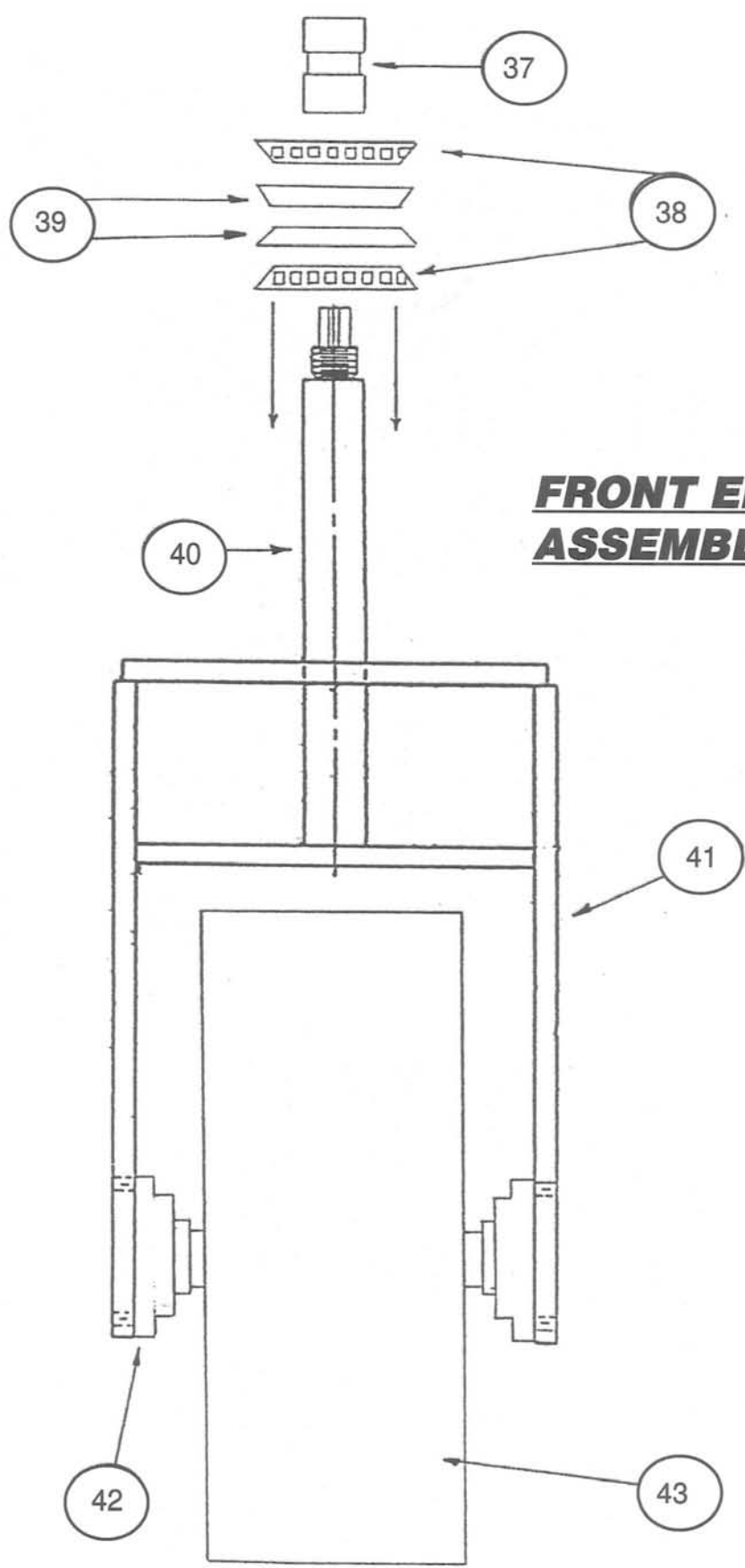

FRONT END
ASSEMBLY:

FRONT END ASSEMBLY:

37.	P498A004	—	Front Drive Coupling
38.	P476A004	—	Inner Race Bearing
39.	P476A005	—	Outer Race
40.	P360B	—	Center Shaft - Steering Fork
41.	P345B	—	Weldment - Front Fork w/Shaft
42.	P432A003	—	Bearing - 2 Hole Flange - 1¼"
43.	P576A007	—	Tire Only
44.	P574A002	—	Tire Tube

SCHEMATICS:

45.	P602A001	—	Seat
46.	P496A002	—	Steering Wheel
47.	P29899A	—	Rubber Seal
48.	P432A003	—	Bearing - 2 Hole Flange 1¼"
49.	P382A	—	Shaft for Agitator
50.	P380C	—	Agitator
51.	P514A002	—	Tire and Wheel Complete
52.	P577A004	—	Split Rim
53.	P579A003	—	Lug Nuts
54.	P488B	—	Choke Cable with Knob
55.	P488T	—	Throttle Cable and Conduit - T Handle
56.	P464A001	—	Locking Gas Cap
57.	P579A002	—	Lug Bolts

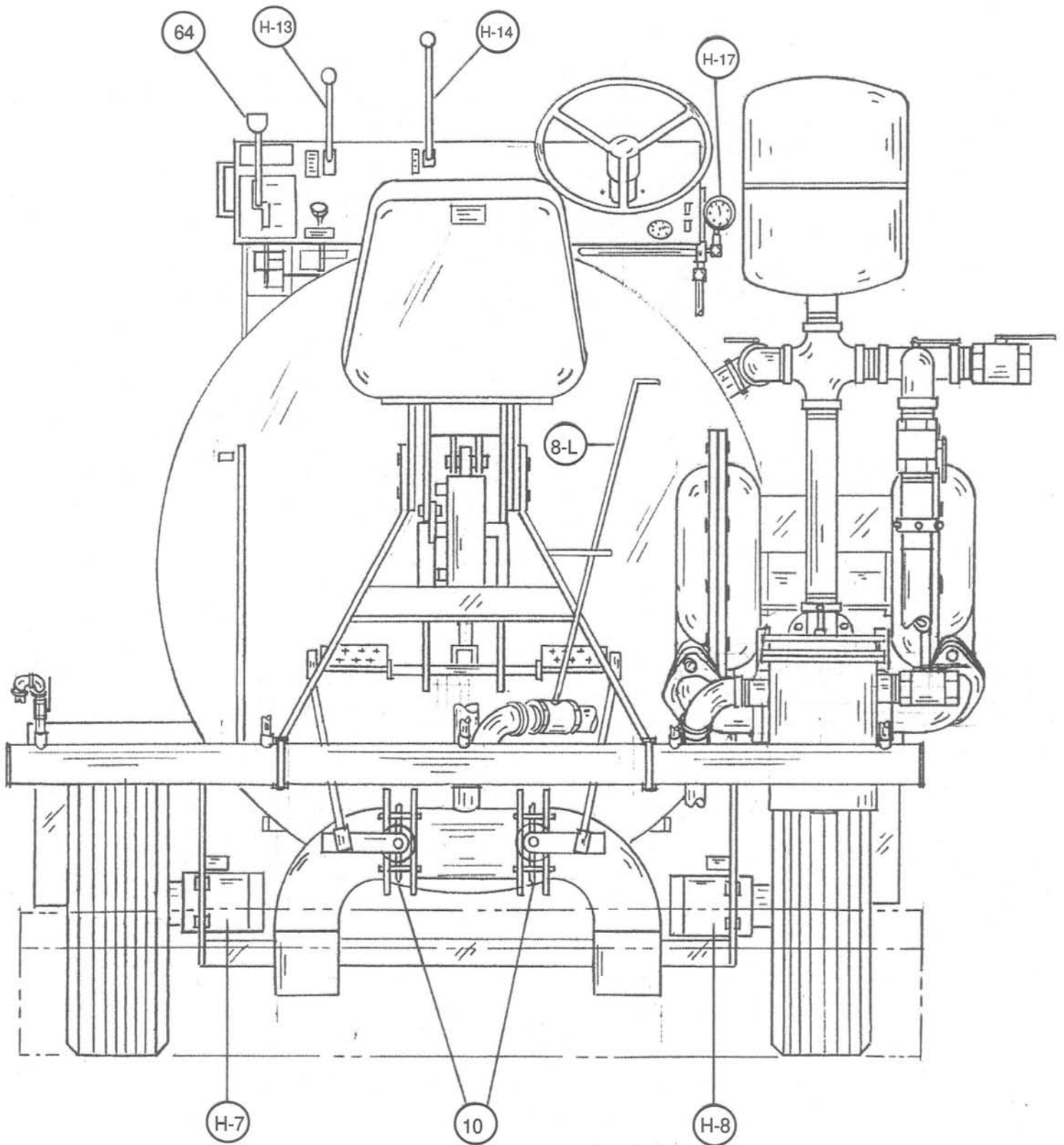

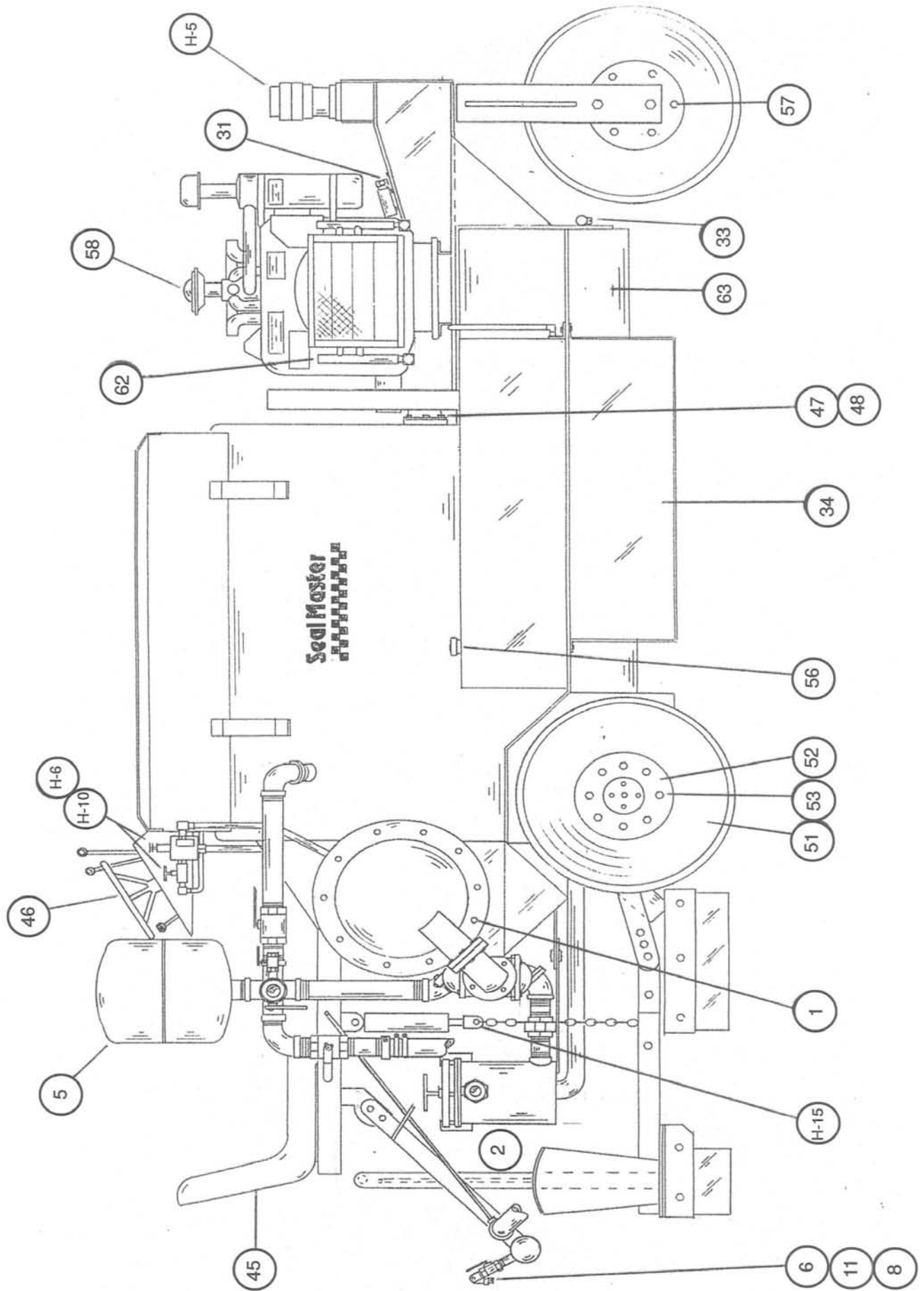

58.	P458A017	—	30 HP Wisconsin Engine
59.	P630A013	—	5016 Chain Coupling (On Wisconsin Engine)
60.	P630A011	—	5016 Chain Coupling (On Transmission)
61.	P631A002	—	5016 Replacement Chain
62.	P716A001	—	Hydraulic Oil Cooler
63.	P938A009	—	Hydraulic Oil
64.	P488A001	—	Forward - Reverse Control
65.	P354B	—	Weldment Front Axle

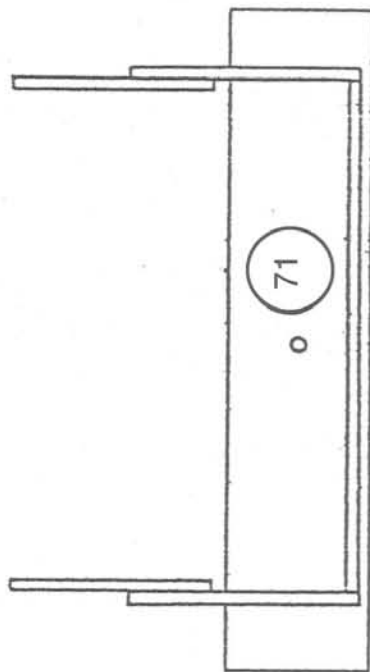
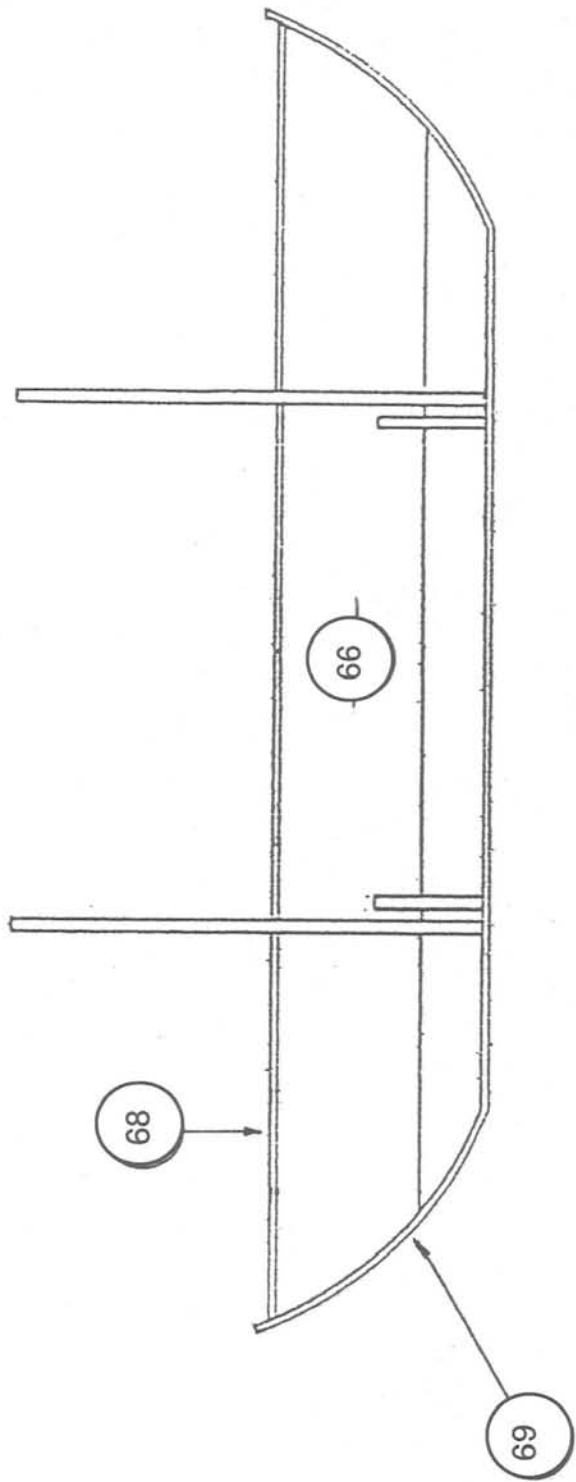

REAR ASSEMBLY:

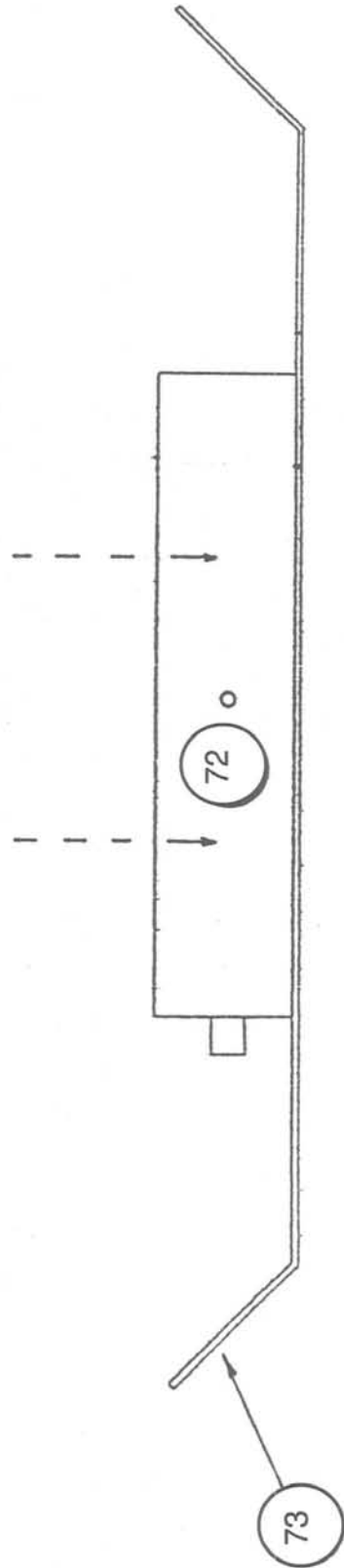

66.	P70001	—	Box Assembly Frame
67.	P109A	—	Back Up Strip x 90" (Also for Rear Assembly)
68.	P109B	—	Back Up Strip x 78"
69.	P459A003	—	3/8" x 6" x 90" Neoprene Rubber
70.	P459A012	—	3/8" x 6" x 80" Neoprene Rubber
71.	P70002	—	Top Rear Assembly Frame
72.	P70003	—	Bottom Rear Assembly Frame
73.	P459A009	—	1/2" x 6" x 90" Neoprene Rubber

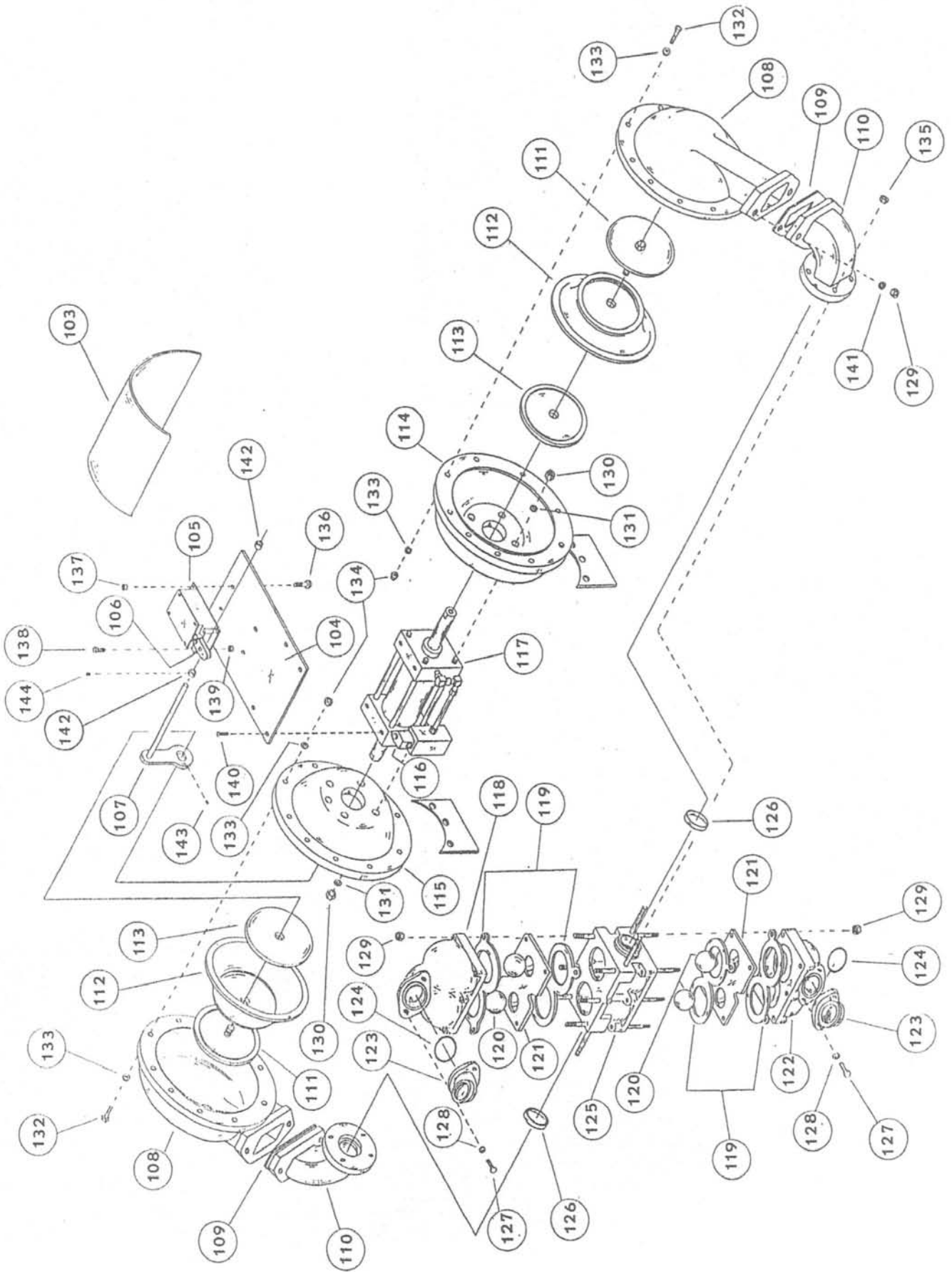

SANDPUMPER II PARTS LIST:

			<u>NUMBER REQUIRED</u>
103.	P966A078	Cover	1
104.	P966A079	Mounting Plate	1
105.	P442A003	Snap Switch	1
106.	P966A080	Lever	1
107.	P966A081	Shifting Arm	1
108.	P966A082	Chamber Diaphragm	2
109.	P966A083	Gasket - Chamber Diaphragm	2
110.	P966A084	Elbow - Chamber Diaphragm	2
111.	P966A085	Plate Assembly - Outer	2
112.	P966A074	Diaphragm - Neoprene	2
113.	P966A086	Plate - Inner	2
114.	P966A087	Chamber Inner - Right	1
115.	P966A088	Chamber Inner - Left	1
116.	P694A001	Electric Coil	1
117.	P600A007	Hydraulic Cylinder	1
118.	P966A066	Discharge Porting Flange	1
119.	P966A068	Gasket - Manifold	4
120.	P966A065	Check Ball - Neoprene	4
121.	P966A072	Seat Assembly	2
122.	P966A067	Suction Porting Flange	1
123.	P966A073	Flange Threaded	2
124.	P966A070	O-Ring	2
125.	P966A069	Manifold	1
126.	P966A071	Sealing Ring	2
127.	P1014A034	1/2" x 1 3/4" Cap Screw	4
128.	P1018A005	1/2" Lock Washer	4
129.	P1021A002	1/2" Lock Nut	12
130.	P1020A005	1/2" Nut	8
131.	P1025A001	1/2" External Tooth Flat Washer	8
132.	P1014A021	3/8" x 2" Cap Screw	20
133.	P1017A003	3/8" Flat Washer	40
134.	P1021A001	3/8" Lock Nut	20
135.	P1021A008	3/8" Nut	4
136.	P1014A039	1/4" x 3/4" Cap Screw	4
137.	P1020A002	1/4" Lock Nut	4
138.	P1014A011	5/16" x 1 1/2" Cap Screw	1
139.	P1021A005	5/16" Lock Nut	2
140.	P1026A001	10 - 32 x 1/2" Machine Screw	4
141.	P1017A005	1/2" Flat Washer	4
142.	P1033A001	3/8" Set Collar	2
143.	P1015A003	1/4 - 28 x 1/2" Set Screw	2
144.	P1015A004	1/4 - 20 x 1/4" Set Screw	2

DISASSEMBLY/ASSEMBLY - DIAPHRAGMS FOR SANDPUMPER II:

1. Changing the diaphragms.
 - A. Measure the gap between flanges.
 - B. Remove the cover from the top of pump.
 - C. Start engine - turn on toggle switch - open the pump speed control - let the actuator rod shift fully to the side of the pump you will be servicing first - close the pump speed control, shut off the toggle switch and the engine.
 - D. Remove all the bolts from around the flanges and the two (2) nuts on the check ball assembly flange.
 - E. Remove the flanged diaphragms chamber.
 - F. Peel back the diaphragm - insert a 1" wrench behind the diaphragm - put the wrench on the flats that are machined on the cylinder rod.
 - G. While holding the 1" wrench on the cylinder rod - put a 1 1/8" wrench to the bolt head, this is welded to the outer support plate. Turn counterclockwise to loosen - remove completely from cylinder rod.
 - H. Remove inner support plate from diaphragm.
 - I. Discard the diaphragm.
 - J. Scrape any dried material from the support plates.
 - K. The new diaphragm is marked "LIQUID SIDE - THIS SIDE OUT" this faces the chamber you took off. Take the outer support plate and insert the bolt through the hole in the diaphragm. The raised head on the diaphragm will fit into the groove of the support plate. Take the inner support plate and slide it onto the bolt coming through the diaphragm, matching the groove to the diaphragm bead. Thread the bolt into the cylinder rod, when snug you can adjust all the diaphragm beads to fit the grooves in the support plates and outer flange.
 - L. Insert the 1" wrench onto the cylinder rod.
 - M. Take a torque wrench set at 55 ft. lbs. and tighten the outer support plate bolt.
 - N. Put the rubber band back on the check ball assembly if it came off with the chamber. Slide the chamber onto the check ball assembly studs and then insert all the flange bolts. Tighten the bolts diagonally until they flanges are drawn down evenly. Set the flange gap to the measurement you took in step A.
2. When changing the side that the actuator rod comes from, follow steps 1.a thorough 1.e. Peel back the diaphragm, the actuator rod is welded to an arm that fits around the cylinder rod. Put your wrench on this arm rather than the flats on the cylinder. Follow the remaining steps.

CHECK BALL ASSEMBLY:

1. Servicing the checkballs
 - A. Loosen the union that is set next to the recirculating or bypass valve.
 - B. Where the plumbing connects to the pump is a flange with two (2) bolts - remove these and lift the discharge piping out of your way. Look for the o-ring that is in this flange.
 - C. The part that this flange connects to contains two (2) check balls. Remove the six (6) locknuts around this manifold, lift up and off of the six (6) studs. Clean out any sand buildup that could keep the balls from seating. Look where the balls sit on the stainless steel seat, sand may cut grooves there - replace if necessary.
 - D. Scrape off the old gaskets and install new gaskets.
 - E. If there is any damage to the check balls replace as necessary.
 - F. Reinstall the manifold and tighten the six (6) locknuts.
 - G. Put grease in the groove in the piping flange and press in a new o-ring. Set discharge piping back on the pump - start the union and then start the two (2) bolts. Tighten the union and finish tightening the two (2) flange bolts.
2. To service the bottom two (2) check balls the procedure is the same. You will loosen the union by the basket strainer.

CAUSE

1. Pump will not cycle.

- A. Basket strainer and lines plugged.
- B. No power coming from toggle switch.
- C. Power at limit switch by not at coil.
- D. Power at coil but does not magnetize cartridge.
- E. Stop collars on actuator rod have moved.
- F. Pressure gauge shows pressure - will go up and down when turning pump pressure control.
- G. Pressure gauge shows pressure but will not go up and down then turning pump pressure control.

2. Pump cycles but will not pump material.

- A. Basket strainer and lines plugged.
- B. Drum suction valve or water flush valve open.
- C. Check ball manifold plugged.
- D. Diaphragm chambers plugged.
- E. Rubber gasket on strainer lid cut.
- F. Main shut off valve stem broken.

3. Material comes out air vent holes.

- A. Diaphragm has ruptured.

4. Material comes out between flanges.

- A. Diaphragm bead has pulled out of groove.

5. Hydraulic oil comes out air vent holes.

- A. Cylinder rod seals leaking.

6. Pump will not go to neutral.

- A. Material is not getting to pump.
- B. Air is trapped in pump.

7. Spray pulsates.

- A. Surge tank is plugged.
- B. Pump is not shifting a complete stroke.
- C. Hydraulic accumulator has lost nitrogen charge.

REMEDY

- A. Clean strainer and lines.
- B. Check fuse and wires.
- C. Check switch to see if contact is made.
- D. Replace coil.
- E. Reposition over marks and tighten.
- F. Relieve hydraulic pressure - remove coil - unscrew cartridge from body - press in on center plunger - it should move 3/16" and spring back to original position - if not, consult with factory for further instructions.
- G. Contamination in pump pressure control - consult with factory for further instruction.

- A. Clean strainer and lines
- B. Close valve.
- C. Remove upper and lower check ball manifolds and clean.
- D. Remove chambers and clean.
- E. Replace rubber gasket.
- F. Replace valve.

- A. Replace diaphragm.

- A. Reset bead or change diaphragms if torn.

- A. Send hydraulic cylinder back to factory for repairs.

- A. See step #2.
- B. Open bypass valve.

- A. Relieve all pressure from the system - remove and clean tank.
- B. One chamber is plugged - remove and clean.
- C. Consult factory.

HOW TO WINTERIZE YOUR EQUIPMENT:

1. Put approximately 50 gallons of water into your mixing tank and agitate well. Then run the water through your pump and spray bar as well as the spray wand. Now that all the lines are clean and the tank is empty, you can start to drain all lines and the pump. Find the lowest point on the system, and either open a valve or remove a plug.

Now locate the suction and discharge manifold and loose the six (6) nuts on each of the manifold that hold it together. Shake the manifold; this makes the check balls move off of their seat and the water then drains away. Open the valves on the spray bar and remove the plugs located on each end. After the water has drained, close the valves. Drain the hand wand hose.

2. Remove the drain plug on the water tank. On the electric water pump, remove the face plate.
3. Disconnect the battery and take it inside if your machine will remain outdoors.
4. Cover the engine with a plastic trash bag.
5. Also put a plastic sandwich bag around each locking cap.
6. If any cylinder rods are exposed, put a thin layer of grease on them.